

# 5568

## ELECTRICITY CONTROLS PERMANENT MAGNETIC CHUCK

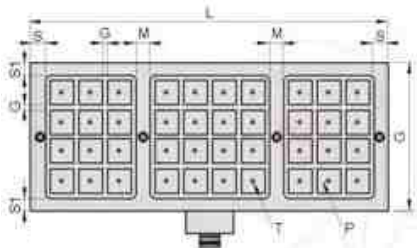
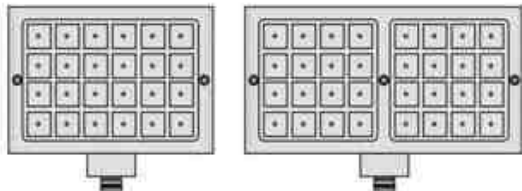

Unit:mm/kg

| Order No.  | Model     | 尺寸  |     |    |    |    |    | Magnetic moment G | magnetic pole Number P | magnetic pole Voltage | Electric current AMP | Weight | Controller Weight | Price |
|------------|-----------|-----|-----|----|----|----|----|-------------------|------------------------|-----------------------|----------------------|--------|-------------------|-------|
|            |           | W   | L   | S  | S1 | M  | T  |                   |                        |                       |                      |        |                   |       |
| 5568-2540  | EPM2540W  | 240 | 430 |    |    | -- |    |                   | 18                     | 18                    | 42                   |        | 30000             |       |
| 5568-2560  | EPM2560W  | 240 | 590 |    |    | 30 |    |                   | 24                     | 24                    | 63                   |        | 36225             |       |
| 5568-2580  | EPM2580W  | 240 | 750 |    |    | 30 |    |                   | 30                     | 30                    | 84                   |        | 45900             |       |
| 5568-2590  | EPM2590W  | 240 | 870 |    |    | 30 |    |                   | 36                     | 36                    | 94                   |        | 50025             |       |
| 5568-25100 | EPM25100W | 240 | 990 |    |    | 30 |    |                   | 42                     | 40                    | 105                  |        | 56100             |       |
| 5568-3030  | EPM3030W  | 300 | 310 |    |    | -- |    |                   | 16                     | 16                    | 38                   |        | 27750             |       |
| 5568-3040  | EPM3040W  | 300 | 430 |    |    | -- |    |                   | 24                     | 24                    | 51                   | 10     | 35250             |       |
| 5568-3060  | EPM3060W  | 300 | 590 |    |    | 30 |    |                   | 32                     | 28                    | 76                   |        | 44925             |       |
| 5568-3080  | EPM3080W  | 300 | 750 |    |    | 30 |    |                   | 40                     | 32                    | 102                  |        | 58200             |       |
| 5568-3090  | EPM3090W  | 300 | 870 |    |    | 30 |    |                   | 48                     | 40                    | 115                  |        | 62250             |       |
| 5568-30100 | EPM30100W | 300 | 990 |    |    | 30 |    |                   | 56                     | 40                    | 127                  |        | 70950             |       |
| 5568-4040  | EPM4040W  | 420 | 430 | 30 | 25 | -- | M8 | 70                | 10                     | 36                    | 18                   |        | 48000             |       |
| 5568-4050  | EPM4050W  | 420 | 480 |    |    | -- |    |                   | 42                     | 26                    | 84                   |        | 54075             |       |
| 5568-4060  | EPM4060W  | 420 | 590 |    |    | 30 |    |                   | 48                     | 24                    | 102                  |        | 61725             |       |
| 5568-4080  | EPM4080W  | 420 | 750 |    |    | 30 |    |                   | 60                     | 30                    | 135                  |        | 80250             |       |
| 5568-4090  | EPM4090W  | 420 | 870 |    |    | 30 |    |                   | 72                     | 36                    | 152                  |        | 90000             |       |
| 5568-40100 | EPM40100W | 420 | 990 |    |    | 30 |    |                   | 84                     | 40                    | 168                  |        | 102750            |       |
| 5568-5060  | EPM5060W  | 480 | 590 |    |    | 30 |    |                   | 56                     | 28                    | 126                  |        | 69375             |       |
| 5568-5080  | EPM5080W  | 480 | 750 |    |    | 30 |    |                   | 70                     | 35                    | 168                  |        | 94500             |       |
| 5568-5090  | EPM5090W  | 480 | 870 |    |    | 30 |    |                   | 84                     | 40                    | 189                  |        | 102000            |       |
| 5568-50100 | EPM50100W | 480 | 990 |    |    | 30 |    |                   | 98                     | 50                    | 210                  |        | 116250            |       |
| 5568-6060  | EPM6060W  | 600 | 590 |    |    | 30 |    |                   | 72                     | 36                    | 152                  |        | 89250             |       |
| 5568-6080  | EPM6080W  | 600 | 750 |    |    | 30 |    |                   | 90                     | 40                    | 203                  | 15     | 116250            |       |
| 5568-6090  | EPM6090W  | 600 | 870 |    |    | 30 |    |                   | 108                    | 45                    | 227                  |        | 127500            |       |
| 5568-60100 | EPM60100W | 600 | 990 |    |    | 30 |    |                   | 126                    | 50                    | 252                  |        | 150000            |       |
| 5568-8080  | EPM8080W  | 750 | 780 |    |    | 30 |    |                   | 120                    | 45                    | 268                  |        | 145500            |       |

# 5750

## UNIVERSAL 3-WAY ANGLE VISE

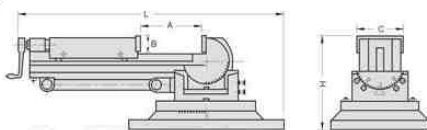

Unit:mm

| Order No. | Model | A   | B  | C   | H   | L   | Vertical Height | N.W. (Kg) | Price |
|-----------|-------|-----|----|-----|-----|-----|-----------------|-----------|-------|
| 5750-03   | VW3   | 90  | 30 | 80  | 150 | 396 | 386             | 17        | 4175  |
| 5750-04   | VW4   | 105 | 38 | 106 | 172 | 460 | 470             | 33        | 4885  |
| 5750-05   | VW5   | 140 | 40 | 132 | 205 | 625 | 590             | 45        | 6815  |

# 5760

## PRECISION ANGLE LOCK MACHINE VISE

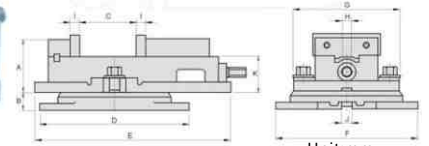

Unit:mm

| Order No | Model |     |        |     |         |     |          |     |        |  | N.W. (Kg) |
|----------|-------|-----|--------|-----|---------|-----|----------|-----|--------|--|-----------|
| 5760-40  | LV40  | 107 | 4      | 154 | 5-15/16 | 220 | 8-9/16   | 271 | 10-1/2 |  | 20        |
| 5760-50  | LV50  | 110 | 4-1/4  | 163 | 6-1/2   | 249 | 9-3/4    | 304 | 12     |  | 29        |
| 5760-60  | LV60  | 138 | 5-1/2  | 201 | 8       | 304 | 12       | 368 | 14-1/2 |  | 41        |
| 5760-80  | LV80  | 198 | 7-3/4  | 264 | 10-3/4  | 402 | 15-13/16 | 476 | 18-3/4 |  | 800       |
| 5760-120 | LV120 | 320 | 12-5/8 | 400 | 15-3/4  | 480 | 18-7/8   | 560 | 22     |  | 125       |

| Model | A   | B       | C  | D        | E   | F      | G   | H      | I   | J        | K   | Price   |     |         |    |       |    |       |    |     |     |         |       |
|-------|-----|---------|----|----------|-----|--------|-----|--------|-----|----------|-----|---------|-----|---------|----|-------|----|-------|----|-----|-----|---------|-------|
| LV40  | 87  | 3-27/64 | 30 | 11-15/16 | 107 | 4      | 242 | 9-1/2  | 318 | 12-33/64 | 230 | 9-1/16  | 172 | 6-3/4   | 14 | 9/16  | 15 | 19/32 | 16 | 5/8 | 58  | 2-9/32  | 2890  |
| LV50  | 98  | 9-55/64 | 32 | 11-1/4   | 110 | 4-1/4  | 280 | 11     | 355 | 14       | 256 | 10-1/16 | 210 | 8-1/4   | 15 | 19/32 | 15 | 19/32 | 16 | 5/8 | 66  | 6-19/32 | 3010  |
| LV60  | 110 | 4-1/4   | 40 | 11-1/2   | 138 | 5-1/2  | 336 | 13-1/4 | 405 | 15-15/16 | 300 | 11-3/4  | 238 | 9-3/8   | 19 | 3/4   | 18 | 3/4   | 18 | 3/4 | 72  | 2-54/64 | 3795  |
| LV80  | 136 | 5-27/64 | 55 | 2-3/16   | 198 | 7-3/4  | 422 | 16-5/8 | 555 | 21-3/4   | 380 | 15      | 305 | 12      | 19 | 3/4   | 24 | 15/16 | 18 | 3/4 | 84  | 3-5/16  | 5620  |
| LV120 | 219 | 8-5/8   | -  | -        | 320 | 12-5/8 | -   | -      | 738 | 28-1/16  | -   | -       | 408 | 16-1/16 | 19 | 3/4   | 24 | 15/16 | -  | -   | 102 | 4       | 18545 |

# 5765

## LOCK-TIGHT PRECISION MACHINE VISE

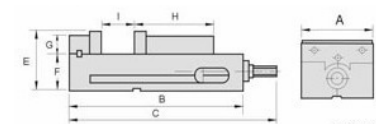

Unit:mm

| Order No | Model | A   | B   | C   | E   | F  | G  | H   | I   | N.W. (Kg) | Price |
|----------|-------|-----|-----|-----|-----|----|----|-----|-----|-----------|-------|
| 5765-40  | LG40  | 100 | 220 | 320 | 133 | 65 | 38 | 115 | 110 | 13kg      | 3105  |
| 5765-50  | LG50  | 125 | 240 | 360 | 146 | 70 | 38 | 132 | 130 | 22kg      | 3280  |
| 5765-60  | LG60  | 150 | 290 | 430 | 161 | 72 | 48 | 170 | 150 | 37kg      | 3450  |
| 5765-80  | LG80  | 200 | 370 | 600 | 193 | 85 | 58 | 190 | 210 | 65kg      | 6730  |

# 5766

## PRECISION ANGLE LOCK MACHINE VISE

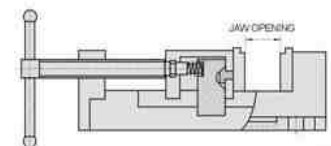

Unit:mm

| Order No. | Model   | JAW PLATE HEIGHT | JAW PLATE HEIGHT | JAW OPENING | N.W. (Kg) | Price |
|-----------|---------|------------------|------------------|-------------|-----------|-------|
| 5766-100  | HDV-100 | 43               | 100              | 90          | 6.6kg     | 1615  |
| 5766-130  | HDV-130 | 43               | 130              | 90          | 8.2kg     | 2280  |

# 5770

## HYDRAULIC MACHINE VISE

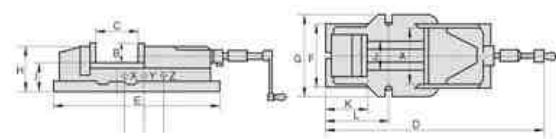

Unit:mm

| Order No | Model  | A   | B  | C   | D   | E   | F   | G   | H   | I   | J   | K   | L   | Clamping Force | N.W.(Kg) Body | N.W.(Kg) Swivel Base | Price |
|----------|--------|-----|----|-----|-----|-----|-----|-----|-----|-----|-----|-----|-----|----------------|---------------|----------------------|-------|
| 5770-100 | HVA100 | 100 | 36 | 170 | 525 | 430 | 130 | 160 | 94  | 60  | 78  | 100 | 155 | 2500           | 16            | 6                    | 4600  |
| 5770-125 | HVA125 | 125 | 46 | 220 | 670 | 540 | 165 | 185 | 118 | 72  | 97  | 117 | 185 | 3500           | 33            | 7                    | 5960  |
| 5770-150 | HVA150 | 150 | 51 | 300 | 800 | 620 | 200 | 240 | 133 | 82  | 116 | 125 | 247 | 4500           | 54            | 16                   | 5160  |
| 5770-200 | HVA200 | 200 | 62 | 300 | 900 | 700 | 225 | 280 | 160 | 100 | 160 | 150 | 265 | 8500           | 90            | 20                   | 9810  |

## 5775

### TILTING HYDRAULIC MACHINE VISE

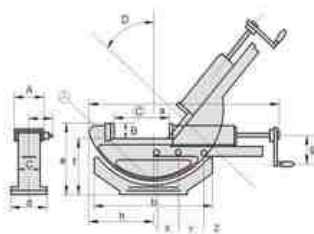

| Order No. | Model  | Unit:mm |    |     |    |     |     |    |     |     |     |     | N.W.(Kg) Body | N.W.(Kg) Swivel Base | Price |       |
|-----------|--------|---------|----|-----|----|-----|-----|----|-----|-----|-----|-----|---------------|----------------------|-------|-------|
|           |        | A       | B  | C   | D  | a   | b   | c  | d   | e   | f   | g   |               |                      |       | h     |
| 5775-100  | HVW100 | 100     | 36 | 170 | 50 | 505 | 325 | 65 | 160 | 177 | 141 | 80  | 170           | 23                   | 4     | 8565  |
| 5775-150  | HVW150 | 150     | 51 | 300 | 50 | 775 | 410 | 95 | 240 | 237 | 186 | 100 | 200           | 60                   | 10    | 10420 |

## 5780

### MECHANICAL POWER MACHINE VISE

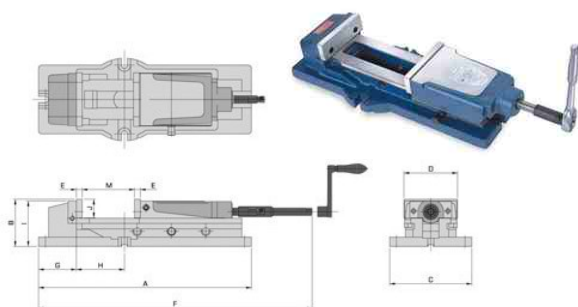

| Order No. | Model | Unit:mm |     |     |     |    |     |     |     |     |    |     | N.W.(Kg) | Price |
|-----------|-------|---------|-----|-----|-----|----|-----|-----|-----|-----|----|-----|----------|-------|
|           |       | A       | B   | C   | D   | E  | F   | G   | H   | I   | J  | M   |          |       |
| 5780-50   | HMP50 | 538     | 118 | 185 | 130 | 15 | 670 | 105 | 82  | 117 | 46 | 220 | 38kg     | 8540  |
| 5780-60   | HMP60 | 620     | 133 | 240 | 154 | 17 | 800 | 110 | 140 | 132 | 54 | 300 | 58kg     | 9015  |
| 5780-80   | HMP80 | 700     | 162 | 280 | 206 | 21 | 900 | 135 | 118 | 160 | 62 | 300 | 105kg    | 16130 |

## 5782

### SUPER OPEN QUICK ACTION VISE

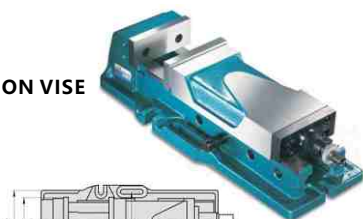
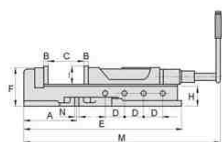

| Order No. | Model  | Unit:mm |    |     |    |     |     |     |    |    |     |     |     |     | N.W.(Kg) | Price |       |
|-----------|--------|---------|----|-----|----|-----|-----|-----|----|----|-----|-----|-----|-----|----------|-------|-------|
|           |        | A       | B  | C   | D  | E   | F   | G   | H  | I  | J   | K   | L   | M   |          |       | N     |
| 5782      | HMP60A | 200     | 18 | 300 | 77 | 610 | 139 | 158 | 82 | 63 | 200 | 240 | 190 | 915 | 18       | 58kg  | 10265 |

## 5785

### PRECISION SUPER VISE

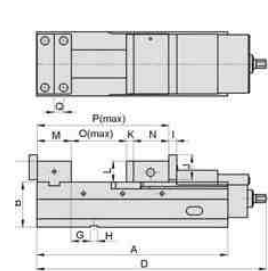

HVL100, 125, 160 is horizontal & vertical 2 way vise.

| Order No. | Model  | Unit:mm |     |     |     |     |       |    |    |    |    |    | N.W.(Kg) | Price |      |     |       |      |      |       |
|-----------|--------|---------|-----|-----|-----|-----|-------|----|----|----|----|----|----------|-------|------|-----|-------|------|------|-------|
|           |        | A       | B   | C   | D   | E   | F     | G  | H  | I  | J  | K  |          |       | L    | M   | N     | O    | P    | Q     |
| 5785-40   | HVL100 | 324     | 85  | 104 | 437 | 130 | 102   | 32 | 18 | 17 | 55 | 15 | 45       | 73    | 86.5 | 140 | 314.5 | 20   | 27kg | 7780  |
| 5785-50   | HVL125 | 390     | 100 | 127 | 480 | 153 | 124.7 | 57 | 18 | 20 | 63 | 15 | 53       | 78    | 87.5 | 201 | 381.5 | 22.5 | 43kg | 9965  |
| 5785-60   | HVL160 | 485     | 115 | 161 | 625 | 168 | 159.2 | 49 | 18 | 20 | 63 | 18 | 53       | 86    | 80   | 295 | 479   | 25   | 71kg | 12810 |

## 5786

### MECHANICAL POWER MACHINE VISE

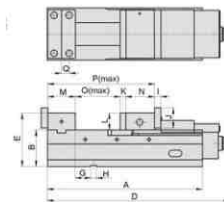

| Order No. | Model   | Unit:mm |     |     |     |     |       |    |    |    |    |    |    |     |      |       |       |      | N.W.(Kg) | Price |
|-----------|---------|---------|-----|-----|-----|-----|-------|----|----|----|----|----|----|-----|------|-------|-------|------|----------|-------|
|           |         | A       | B   | C   | D   | E   | F     | G  | H  | I  | J  | K  | L  | M   | N    | O     | P     | Q    |          |       |
| 5786-40   | HVQ100  | 324     | 85  | 104 | 428 | 130 | 102   | 32 | 18 | 17 | 55 | 15 | 45 | 73  | 86.5 | 140   | 314.5 | 20   | 30kg     | 11385 |
| 5786-50   | HVQ125  | 390     | 100 | 127 | 495 | 153 | 124.7 | 57 | 18 | 20 | 63 | 15 | 53 | 78  | 87.5 | 201   | 381.5 | 22.5 | 46kg     | 12810 |
| 5786-60   | HVQ160  | 485     | 115 | 161 | 605 | 168 | 159.2 | 49 | 18 | 20 | 63 | 18 | 53 | 86  | 80   | 295   | 479   | 25   | 71kg     | 15940 |
| 5786-60L  | HVQ160L | 515     | 115 | 161 | 635 | 168 | 159.2 | 67 | 18 | 20 | 63 | 18 | 53 | 86  | 80   | 330   | 514   | 25   | 76kg     | 20400 |
| 5786-80   | HVQ200  | 535     | 120 | 202 | 655 | 178 | 199.5 | 66 | 18 | 20 | 73 | 18 | 58 | 101 | 95   | 320   | 534   | 31   | 100kg    | 17080 |
| 5786-80L  | HVQ200L | 585     | 120 | 202 | 713 | 178 | 200   | 84 | 18 | 20 | 73 | 18 | 58 | 101 | 95   | 367.5 | 581.5 | 31   | 108kg    | 20880 |

## 5788

### MULTI-POWER CNC PRECISION FIXED ANGLE VISE

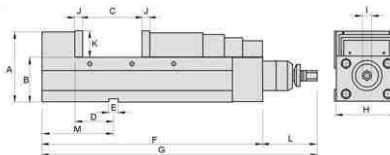

| Order No. | Model   | Unit:mm |          |       |        |         |         |          |    |     |     |     |    |    |    |     |     |    | N.W.(Kg) | Price |
|-----------|---------|---------|----------|-------|--------|---------|---------|----------|----|-----|-----|-----|----|----|----|-----|-----|----|----------|-------|
|           |         | A       | B        | C     | C1     | C2      | C3      | D        | E  | F   | G   | H   | I  | J  | K  | L   | M   |    |          |       |
| 5788-130  | HPAC130 | 147     | 95±0.01  | 0-190 | 70-260 | 115-305 | 185-375 | 80±0.02  | 18 | 475 | 583 | 131 | 19 | 15 | 55 | 120 | 150 | 47 | 13715    |       |
| 5788-160  | HPAC160 | 160     | 105±0.01 | 0-250 | 85-325 | 140-375 | 220-460 | 80±0.02  | 18 | 560 | 670 | 161 | 19 | 15 | 58 | 120 | 165 | 65 | 16390    |       |
| 5788-200  | HPAC200 | 170     | 110±0.01 | 0-290 | 90-380 | 155-440 | 240-530 | 100±0.02 | 18 | 635 | 743 | 201 | 19 | 18 | 63 | 120 | 197 | 95 | 21565    |       |

## 5792

### Two-dimensional vector vise

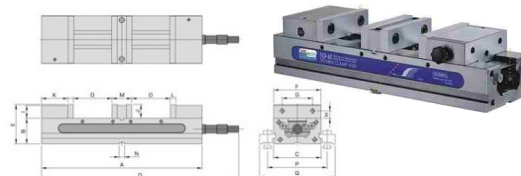

| Order No. | Model | Unit:mm |       |     |     |        |     |      |      |      |      |      |    |    |    |     |     |     | N.W.(Kg) | Price |
|-----------|-------|---------|-------|-----|-----|--------|-----|------|------|------|------|------|----|----|----|-----|-----|-----|----------|-------|
|           |       | A       | B     | C   | D   | E      | F   | G    | H    | I    | J    | K    | L  | M  | N  | O   | P   | Q   |          |       |
| 5792-40   | TLD40 | 405     | 63.5  | 104 | 459 | 101.5  | 102 | 63.5 | 17.5 | 33   | 38   | 69   | 15 | 55 | 18 | 90  | 143 | 195 | 20kg     | 11385 |
| 5792-60   | TLD60 | 520     | 82.55 | 154 | 536 | 127.05 | 152 | 98.4 | 23.8 | 41.5 | 44.5 | 86.5 | 15 | 66 | 18 | 125 | 193 | 245 | 52kg     | 13285 |

## 5796

### MC PRECISION SUPER HI-PRESSURE RAPID VISE



尺寸圖 DIMENSIONS

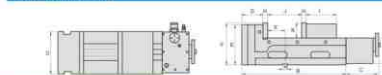

DIMENSIONS FOR 4 JAW PLATE POSITIONS



| Order No. | Model   | Unit:mm |     |     |     |     |     |    |    |     |       |         |         |         |    |     |    |    | Gripping N.W.(Kg) | Price |       |
|-----------|---------|---------|-----|-----|-----|-----|-----|----|----|-----|-------|---------|---------|---------|----|-----|----|----|-------------------|-------|-------|
|           |         | A       | B   | C   | D   | E   | F   | G  | H  | I   | J     | J1      | J2      | J3      | K  | L   | M  | X  |                   |       |       |
| 5796-01   | TPV5150 | 520     | 380 | 140 | 130 | 157 | 160 | 86 | 15 | 110 | 0-150 | 95-250  | 110-275 | 200-300 | 55 | 105 | 18 | 45 | 6000              | 45    | 15830 |
| 5796-02   | TPV6160 | 540     | 400 | 140 | 160 | 160 | 163 | 86 | 15 | 120 | 0-160 | 95-260  | 120-295 | 210-400 | 55 | 105 | 18 | 45 | 6000              | 47    | 17680 |
| 5796-03   | TPV6250 | 630     | 490 | 140 | 160 | 160 | 163 | 86 | 15 | 120 | 0-250 | 95-350  | 120-395 | 210-490 | 55 | 105 | 18 | 45 | 6000              | 53    | 18720 |
| 5796-04   | TPV7200 | 600     | 460 | 140 | 180 | 170 | 173 | 90 | 18 | 130 | 0-200 | 100-300 | 130-350 | 220-460 | 63 | 110 | 18 | 72 | 9000              | 65    | 19750 |
| 5796-05   | TPV8200 | 610     | 470 | 140 | 200 | 170 | 173 | 90 | 18 | 140 | 0-200 | 100-310 | 140-360 | 230-470 | 63 | 110 | 18 | 72 | 9000              | 70    | 21735 |
| 5796-06   | TPV8300 | 710     | 570 | 140 | 200 | 170 | 173 | 90 | 18 | 140 | 0-300 | 100-410 | 140-460 | 230-570 | 63 | 110 | 18 | 72 | 9000              | 79    | 22900 |

## 5810-5812

### SEMI-UNIVERSAL CENTER (DIVIDING HEAD)

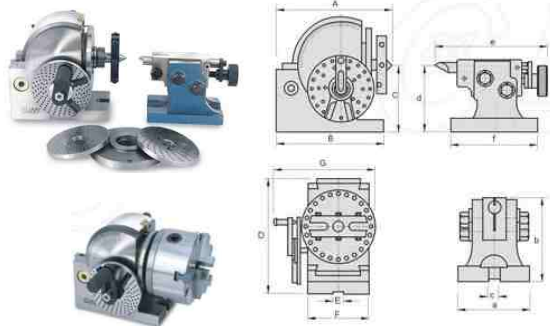

SEMI-UNIVERSAL INDEX CENTER B & S TYPE NO.0 , NO.1(HEAD-STOCK) Unit:mm

| Order No. | Model | A   | B      | C   | D       | E   | F      | G   | N.W.(Kg) | Price |     |     |        |     |        |    |      |
|-----------|-------|-----|--------|-----|---------|-----|--------|-----|----------|-------|-----|-----|--------|-----|--------|----|------|
| 5810      | BS0   | 189 | 77/16  | 160 | 6 19/54 | 100 | 315/16 | 173 | 613/16   | 16    | 5/8 | 91  | 337/64 | 140 | 533/64 | 22 | 7420 |
| 5812      | BS1   | 293 | 111/32 | 210 | 8 17/64 | 128 | 53/64  | 220 | 53/64    | 16    | 5/8 | 114 | 431/64 | 156 | 6 9/64 | 36 | 9750 |

SEMI-UNIVERSAL INDEX CENTER B & S TYPE NO.0 , NO.1(TAIL-STOCK) Unit:mm

| Model | a   | b      | c   | d     | e  | f   | Taper of Center | Diameter of Spindle hole |     |        |     |        |          |    |
|-------|-----|--------|-----|-------|----|-----|-----------------|--------------------------|-----|--------|-----|--------|----------|----|
| BS0   | 90  | 335/54 | 105 | 49/64 | 16 | 5/8 | 100             | 315/16                   | 166 | 634/64 | 127 | 5      | 8&S No.7 | 18 |
| BS1   | 108 | 41/4   | 134 | 59/32 | 16 | 5/8 | 128             | 529/32                   | 184 | 71/4   | 150 | 529/32 | 8&S No.9 | 20 |

#### STANDARD ACCESSORIES

Dividing plate A,B,C.

Numbers of holes of dividing plate(worm gear reduction ratio 1:40) Unit:mm

| Numbers of holes | PlateA | 15 | 16 | 17 | 18 | 19 | 20 |
|------------------|--------|----|----|----|----|----|----|
|                  | PlateB | 21 | 23 | 27 | 29 | 31 | 33 |
|                  | PlateC | 37 | 39 | 41 | 43 | 47 | 49 |

## 5820

### HORIZONTAL AND VERTICAL ROTARY TABLE

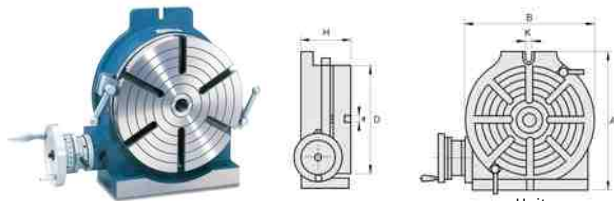

| Order No. | Model | Table |     | Base Dimension |     | Bolt Slots K | Center sleeve | Worm Gear Ratio | N.W.(Kg) | Price |
|-----------|-------|-------|-----|----------------|-----|--------------|---------------|-----------------|----------|-------|
|           |       | D     | H   | A              | B   |              |               |                 |          |       |
| 5820-15   | HV150 | 150   | 92  | 220            | 160 | 18           | MT-2          | 90 1            | 12.5     | 3880  |
| 5820-20   | HV200 | 200   | 120 | 310            | 225 | 18           | MT-3          |                 | 31.0     | 5450  |
| 5820-25   | HV250 | 250   | 120 | 320            | 280 | 18           | MT-3          |                 | 48.5     | 6790  |
| 5820-30   | HV300 | 300   | 140 | 410            | 325 | 18           | MT-4          |                 | 77.0     | 8660  |
| 5820-35   | HV350 | 350   | 140 | 460            | 380 | 18           | MT-4          |                 | 98       | 11095 |
| 5820-40   | HV400 | 400   | 140 | 510            | 435 | 18           | MT-5          |                 | 130      | 16045 |

## 5821

### TAIL STOCK

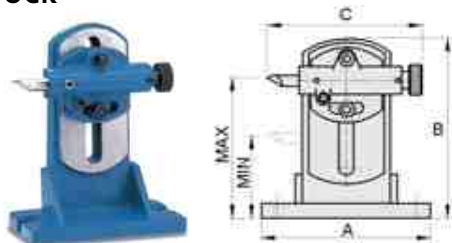

| Order No. | Model | Suitable for  | A   | B   | C   | Center Height |      | N.W.(Kg) | Price |
|-----------|-------|---------------|-----|-----|-----|---------------|------|----------|-------|
|           |       |               |     |     |     | Max.          | Min. |          |       |
| 5821-01   | TS1   | HV-200/HV-250 | 230 | 247 | 210 | 190           | 110  | 13       | 1440  |
| 5821-02   | TS2   | HV-300        | 230 | 280 | 210 | 220           | 140  | 15       | 1520  |
| 5821-03   | TS3   | HV-350/HV-400 | 230 | 330 | 210 | 264           | 184  | 17       | 1900  |

## 5865

### ANGLE PLATE+CONNECTING PLATE+SWIVELBASE

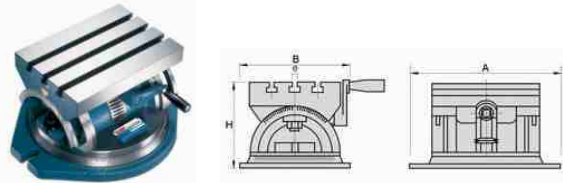

| Order No. | Model   | A   | B   | H   | T-SLOT e | N.W.(Kg) | Price |
|-----------|---------|-----|-----|-----|----------|----------|-------|
|           |         |     |     |     |          |          |       |
| 5865-02   | HAP250S | 350 | 305 | 185 | 12       | 40       | 8025  |
| 5865-03   | HAP380S | 490 | 436 | 240 | 16       | 100      | 12075 |

## 5855

### UNIVERSAL TILTING ROTARY TABLE

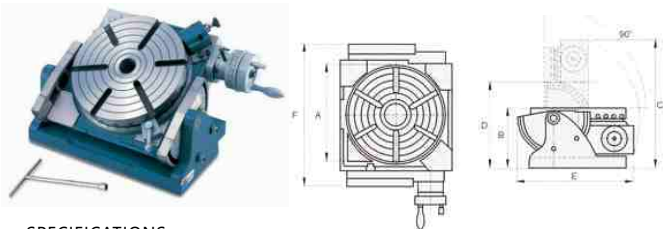

| Order No. | Model | Table Diameter A | Table Height Horizontal(B) | Table Height Vertical(C) | Center Height Vertical(D) | E | F | Gear Ratio | Center Hole | Direct Indexing | N.W.(Kg) |
|-----------|-------|------------------|----------------------------|--------------------------|---------------------------|---|---|------------|-------------|-----------------|----------|
|           |       |                  |                            |                          |                           |   |   |            |             |                 |          |

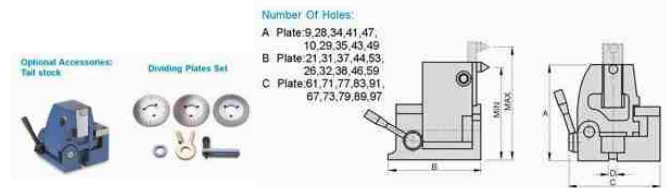

| Order No. | Model  | A   | B   | C   | D  | Center Height |     | N.W.(Kg) | Price |
|-----------|--------|-----|-----|-----|----|---------------|-----|----------|-------|
|           |        |     |     |     |    | Max           | Min |          |       |
| 5855      | HUT300 | 200 | 196 | 190 | 16 | 230           | 113 | 23       | 27420 |

