

6600

END MILL RE-SHARPENER MG413

¥18400



Model	6600
Drill Diameter	φ4mm~φ13mm
Point Angle	
Dresser	SDC diamond grinding wheel #300 (for 4mm-6mm) SDC diamond grinding wheel #300/#120 (for 7mm-13mm)
Motor	3/4HP 450W
R.P.M	6000R.P.M
Power Supply	AC110V/AC220V(Single-phase)
Weight	17kg

Model	Vocts
6600-110	110V
6600-220	220V

6602-01

DRILL RESHARPENING MACHINE DG213

¥9200



Model	66002-01
Drill Diameter	Φ2mm~Φ13mm
Point Angle	90°~135°
Power Supply	AC110V/AC220V(Single-phase)
Motor	1/3HP 250W
R.P.M	5500R.P.M
Weight	8.5kg

Model	Vocts
6602-01-110	110V
6602-01-220	220V

6602-02

DRILL RESHARPENING MACHINE DG1226

¥18395



Model	66002-02
Drill Diameter	Φ12mm~Φ26mm
Point Angle	90°~135°
Power Supply	AC110V/AC220V(Single-phase)
Motor	1/2HP 450W
R.P.M	2500R.P.M
Weight	26kg

Model	Vocts
6602-02-110	110V
6602-02-220	220V

6603

UNIVERSAL GRINDING CUTTER U2



¥16100

Specifications:
Maximum clamping diameter: 18mm
Max grinding diameter: 25mm
Taper angle: 0~180°
Clearance angle: 0~45°
Negative cone angle: 0~26°
Spindle speed: 3600rpm
Blood type grinding wheel diameter: 100 x 50 x 20mm
Motor: 1/3HP 220V/380V 50/60Hz
Machine size: L450×W400 ×H350mm

6605

HIGH SPEED CUT-OFF MACHINE TY280

¥12420



Order No.	Model	Maximum cut-off range	Cutting tolerance	Grinding wheel size
6605-110	TY280-110	φ20 100mm(W)	20±0.10mm	150mm 1mm 19.05mm
6605-220	TY280-220	φ20 100mm(W)	20±0.10mm	150mm 1mm 19.05mm

Order No.	Model	Speed R.P.M	Voltage (Single-phase)	Length of positioning ruler	weight (kg)
6605-110	TY280-110	3600	1/2HP 110	300mm	86
6605-220	TY280-220	3600	1/2HP 220	300mm	86

6608

PRECISION CUTTING & MILLING MACHINE

TY300, 500, 600



- 1.Suitable for die, round tip, stainless steel and so on
- 2.Cutting, grinding once completed, can shorten the working time, accurate cutting angle
- 3.Rapid fixture design, easy to hold fast
- 4.Trimming micrometer, quick positioning dimensions
- 5.Grinding wheel, can be used to adjust the rest at any time, the same size
- 6.High stability, low wear rate, long service life
- 7.Size: L430× W380 ×H540mm

Note: "CE" is a European security certification mark

Order No.	Model	cutting precision	right angle precision	Grinding wheel size	Speed R.P.M	Voltage (Single-phase)	length of positioning ruler	weight (kg)	Price				
6608-01	TY-300×110V	φ25×300 ±0.03	φ25×90° ±0.03	WA46K ×100 ×50 ×20	3600	3/4HP 110	300mm	87.5	-				
6608-02	TY-300×110V-CE					3/4HP 110-CE	300mm	87.5	-				
6608-03	TY-300×220V					3/4HP 220	300mm	87.5	22500				
6608-04	TY-300×220V-CE					3/4HP 220-CE	300mm	87.5	-				
6608-05	TY-300×380V					3/4HP 380	300mm	87.5	20000				
6608-06	TY-300×380V-CE					3/4HP 380-CE	300mm	87.5	-				
6608-07	TY-500×110V					φ25×300 ±0.02	φ25×90° ±0.02	WA46K ×100 ×50 ×20	3600	3/4HP 110	500mm	91.5	-
6608-08	TY-500×110V-CE									3/4HP 110-CE	500mm	91.5	-
6608-09	TY-500×220V									3/4HP 220	500mm	91.5	23100
6608-10	TY-500×220V-CE									3/4HP 220-CE	500mm	91.5	-
6608-11	TY-500×380V	3/4HP 380	500mm	91.5	20600								
6608-12	TY-500×380V-CE	3/4HP 380-CE	500mm	91.5	-								
6608-13	TY-600×110V	φ25×300 ±0.01	φ25×90° ±0.01	WA46K ×100 ×50 ×20	3600					3/4HP 110	600mm	93.5	-
6608-14	TY-600×110V-CE									3/4HP 110-CE	600mm	93.5	-
6608-15	TY-600×220V									3/4HP 220	600mm	93.5	23700
6608-16	TY-600×220V-CE									3/4HP 220-CE	600mm	93.5	-
6608-17	TY-600×380V					3/4HP 380	600mm	93.5	21200				
6608-18	TY-600×380V-CE					3/4HP 380-CE	600mm	93.5	-				

6609

V SHAPED CHAMFERING MACHINE (FACE MILLING CUTTER TYPE) ¥8025

Order No.	Model	Chamfer capacity	Speed	Voltage	Net weight	Gross weight	Packing size
6609-110				110V			
6609-220	VCM500	0~3mm	3600R.P.M	220V	26kg	28kg	53×42×41cm
6609-380				380V			



6609-01

V SHAPED CHAMFERING MACHINE (GRINDING WHEEL TYPR)

¥8025

Order No.	Model	Chamfer capacity	Speed	Voltage	Net weight	Gross weight	Packing size
6609-01-110				110V			
6609-01-220	VCMW500	0~3mm	3600R.P.M	220V	26kg	28kg	53×42×41cm
6609-01-380				380V			



6610

SIDE MILLING CHAMFERING MACHINE GH500A



¥5230

Specifications:
Size: L500 × W320 × H320
Voltage: single phase 110V/220V,
three-phase 220V/380V
HP: 1HP.50~60Hz
Speed: 3500R.P.M
Chamfer height: 0~3mm
Chamfer adjustment angle range: 15° ~45°

6610-01

¥7335

CHAMFERING MACHINE (SIDE CUTTER TYPE) CMS500



Order No.	Model	Chamfer capacity	Speed	Voltage	Net weight	Gross weight	Packing size
6610-01-110	CMS500	0~3mm	3600R.P.M	110V	28kg	30kg	53×42×41cm
6610-01-220				220V			
6610-01-380				380V			

6613

FLAT SURFACE MILLING CHAMFERING MACHINE

GH500B



¥5920

Specifications:
Size: L500 × W320 × H460
Voltage: single phase 110V/220V,
three-phase 220V/380V
HP: 1HP.50~60Hz
Speed: 3500R.P.M
Chamfer height: 0~3mm
Chamfer adjustment angle range: 45°

6613-01

¥8025

CHAMFERING MACHINE (FACE MILLING CUTTER TYPE) CMC500N



Order No.	Model	Chamfer capacity	Speed	Voltage	Net weight	Gross weight	Packing size
6613-01-110	CMC500N	0~3mm	3600R.P.M	110V	29kg	31kg	53×42×41cm
6613-01-220				220V			
6613-01-380				380V			

6615

BOWI WHEEL CHAMFERING MACHINE GH500C



¥5920

Specifications:
Size: L500 × W320 × H320mm
Wheel size: 125 x 31.75 x thick 50mm.#60 (V6 type)
Voltage: single phase 110V/220V,
three-phase 220V/380V
HP: 1HP.50~60Hz
Slide length: 500mm
Speed: 3500R.P.M
Chamfer height: 0~3mm
Chamfer angle: 45°

¥7765

CHAMFERING MACHINE (GRINDING WHEEL TYPE) CMW500N



Order No.	Model	Chamfer capacity	Speed	Voltage	Net weight	Gross weight	Packing size
6615-01-110	CMW500N	0~3mm	3600R.P.M	110V	28kg	30kg	53×42×41cm
6615-01-220				220V			
6615-01-380				380V			

6620

DISK ESPER CHAMFERING MACHINE GH300

¥6990



Specifications:
Size: L380 × W320 × H310mm
Wheel size: 165 22mm diameter
Voltage: single phase 110V/220V,
three-phase 220V/380V
HP: 1HP.50~60Hz
Slide length: 500mm
Speed: 3500R.P.M
Chamfer height: 0~3mm
Chamfer angle: 45°

6620-01

¥6210

CHAMFERING MACHINE (SANDING WHEEL TYPE) CMS320



Order No.	Model	Chamfer capacity	Speed	Voltage	Net weight	Gross weight	Packing size
6620-01-110	CMS320	0~1mm	3600R.P.M	110V	24kg	26kg	53×42×41cm
6620-01-220				220V			

6625

PORTABLE REGULAR TYPE CHAMFERING MACHINE GH320C/R/S

¥4055



Specifications:
Blade specification: 9.525mm
(SPMW090304)
Perforated square blade
Voltage: single phase 110V/220V
HP: 500W
Speed: 8000R.P.M
Chamfering depth: 0-3mm

6625

VERTICAL HAND CHAMFERING TOOL VHCT

¥4055



Order No.	Model	Chamfer capacity	Speed	Voltage	Net weight	Gross weight	Packing size
6625-01-03HG-110	VHCT-03HG	3mm	1200R.P.M	110V	2.5kg	2.8kg	36×13.5×12.5cm
6625-01-03HG-220				220V			

6626

¥4200

STRONG PORTABLE CHAMFERING MACHINE GH320A



Specifications:
Size:
L360 × W200 × H260mm
Voltage: 220V/380V
HP: 0.5HP
Slide length: 200mm
Speed: 50/60Hz 3500R.P.M
Chamfer adjustment angle
range: 15° ~45°
Chamfering depth: 0-9mm

6627

¥3925

AIR HAND CHAMFERING TOOL AHCT



Order No.	Model	Chamfer capacity	Speed	wind pressure	Net weight	Gross weight	Packing size
6627	AHCT-03	3mm	1200R.P.M	90psi/63kg/cm	2.5kg	2.9kg	36×13.5×12.5cm

6628

¥3710

IRREGULAR TYPE CHAMFERING TOOL IHCT



Order No.	Model	倒角能力	回转速	电压	净重	毛重	装箱尺寸	备注
6628-03HG-110	IHCT-03HG	0~3mm	1200R.P.M	110V	2.2kg	2.4kg	36×13.5×12.5cm	日制电机
6628-03HG-220				220V				

5485

UNIVERSAL ARM MAGNETIC BASE

320、340、360

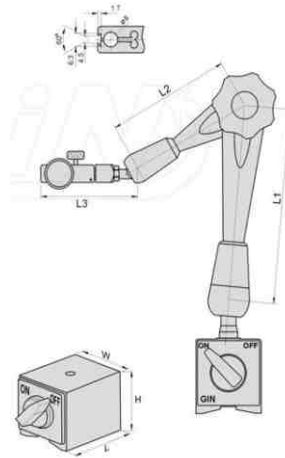

Unit:mm

Order No.	Model	Power Holding	Arm Length			Base Dimension			N.W.	Price
			L1	L2	L3	L	W	H		
5485-08	320	80kgf	112	102	65	60	50	55	1.4kg	560
5485-09	340	80kgf	135	110	70	60	50	55	1.6kg	1080
5485-10	360	100kgf	145	130	80	80	50	55	2.1kg	1350

5486

UNIVERSAL ARM MAGNETIC BASE

300A、300AL、300ALL

Precision type hydraulic arm

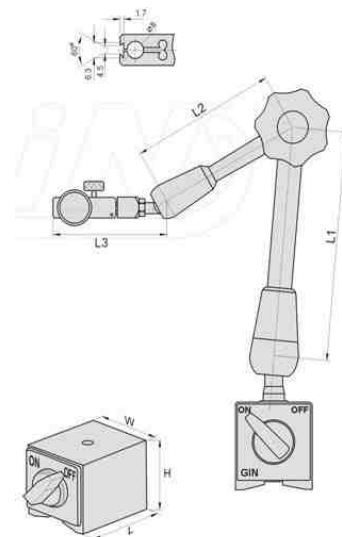



Unit:mm

Order No.	Model	Power Holding	Arm Length			Base Dimension			N.W.	Price
			L1	L2	L3	L	W	H		
5486-01	300A	100kgf	120	118	70	80	50	55	2.3kg	2245
5486-02	300AL	100kgf	168	166	70	80	50	55	2.5kg	2768
5486-03	300ALL	160kgf	285	280	95	120	50	55	3.5kg	5995



LIFTING PARAMETERS

Lifting form	Maximum lifting load kg	Minimum thickness mm	Maximum length mm	Maximum diameter mm	
 Face	Max×250	250	20	1500	--
	Max×500	500	25	2000	--
	Max×1000	1000	40	3000	--
	Max×1500	1500	45	3000	--
	Max×2000	2000	55	3000	--
 Round	Max×250	100	10	1500	300
	Max×500	200	15	2000	400
	Max×1000	400	25	3000	450
	Max×1500	600	30	3000	500
	Max×2000	800	35	3000	600

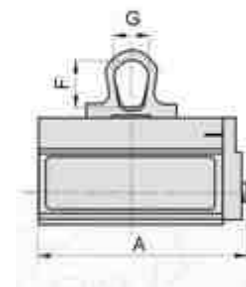
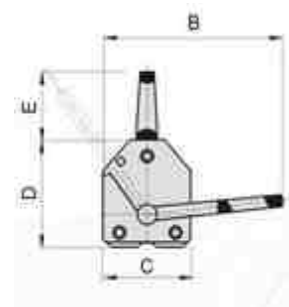

Precision : ± 0.005

Unit:mm

Order No.	Model	A	B	C	D	E	F	G	N.W. (Kg)	Price
5566-250	Max×250	189	185	79	79	63	35	43	6	7500
5566-500	Max×500	249	358	106	101	88	52	60	15	13200
5566-1000	Max×1000	342	316	133	131	88	52	60	34	19200
5566-1500	Max×1500	383	457	166	171	122	64	87	66	29550
5566-2000	Max×2000	457	457	166	171	122	64	87	80	35400