

2-Jaw High Speed Hollow Power Chucks

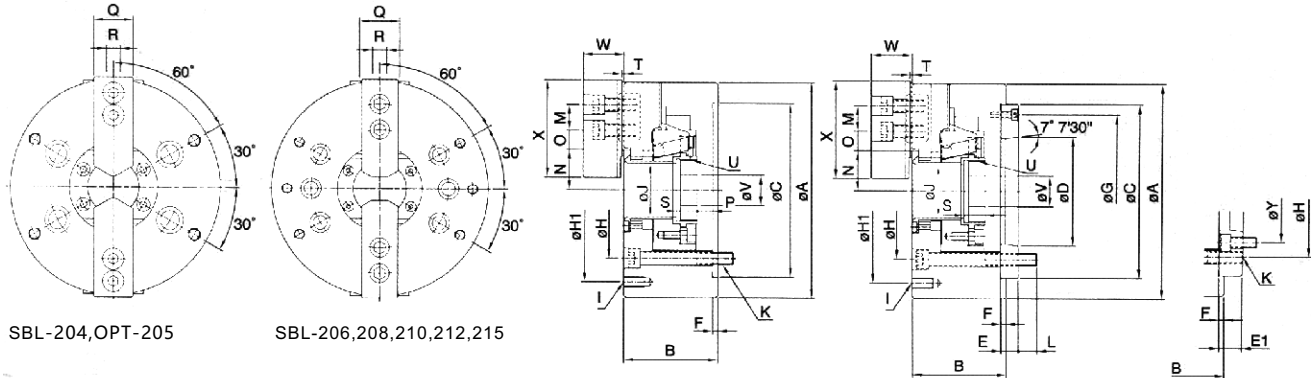

>>Dimensions



>>Specifications

Order Number	MODEL	Nose Of Spindle	A	B	C (h6)	D	E	E1	F	G	H	H1	I	J	K	L
701100	SBL-204	--	110	59	85	--	--	--	4	--	70.6	--	--	26	4-M10x1.5P	--
701102	SBL-205	A ₂ -4	135	60	110	63.513	20	--	4	96	82.6	PCDØ118	4-M8x1.25P	33	4-M10x1.5P	15
701104	SBL-206	A ₂ -5	169	81	140	82.563	15	--	5	116	104.8	PCDØ145	6-M10x1.5P	45	6-M10x1.5P	16
701106	SBL-208	A ₂ -6(A ₂ -5)	210	91	170	106.375	17	23	5	150	133.4	PCDØ180	6-M10x1.5P	52	6-M12x1.75P	18
701108	SBL-210	A ₂ -8(A ₂ -6)	254	100	220	139.719	18	28	5	190	171.4	PCDØ225	6-M12x1.75P	75	6-M16x2P	19
701110	SBL-212	A ₂ -8	304	110	220	139.719	18	--	6	190	171.4	PCDØ250	6-M12x1.75P	91	6-M16x2P	25
701112	SBL-215	A ₂ -11(A ₂ -8)	381	133	300	196.869	22	33	6	260	235	PCDØ324	6-M12x1.75P	117.5	6-M20x2.5P	28

MODEL	M	N _{max.}	N _{min.}	O _{max.}	O _{min.}	P _{max.}	P _{min.}	Q	R	S	T	U	V	W	X	Y	Thru-Hole [Diameter] (mm)	Plunger Stroke (mm)
SBL-204	14	23	20.3	11.5	6.7	3.5	-6.5	23	10	17.5	2	M32x1.5P	12	24	49.5	--	26	10
SBL-205	14	26.2	23.5	19	6	1	-9	25	10	20	2	M40x1.5P	12	31.5	62	--	33	10
SBL-206	20	32.35	29.6	24	7	11	-1	31	12	19	2	M55x2P	20	37	73	--	45	12
SBL-208	25	39.1	35.4	30	10	14.5	-1.5	35	14	20.5	2	M60x2P	30	39	95	104.8	52	16
SBL-210	30	51.5	47.1	34	12	8.5	-10.5	40	16	25	2	M85x2P	40	43	110	133.4	75	19
SBL-212	30	61.6	56.3	46	12	8	-15	50	21	28	2	M100x2P	50	51	129	--	91	23
SBL-215	43	82.3	77	46	13	7	-16	62	22	42.5	5	M130x2P	48	66	165	171.4	117.5	23

MODEL	Jaw Stroke [Diameter] (mm)	Max.Speed r.p.m.(min-1)	Max.Pull Force kgf (kN)	Max.Gripping Force kgf (kN)	Max.Hydr. Pressure kgf/cm ² (Mpa)	Weight (kg)	Matching Cylinder	Gripping Range	Price
SBL-204	5.4	8000	920 (9)	1930 (19)	15.5 (1.5)	3.6	SH1036	Ø7 ~Ø110	
SBL-205	5.4	7000	1120 (11)	2340 (23)	19 (1.9)	6.5	SH1036	Ø10 ~Ø135	8300
SBL-206	5.5	6000	1420 (14)	3770 (37)	18.5 (1.8)	13.1	SH1246	Ø13 ~Ø169	9300
SBL-208	7.4	5000	2240 (22)	5710 (56)	17 (1.7)	23.0	SH1552	Ø13 ~Ø210	10300
SBL-210	8.8	4200	2850 (28)	7440 (73)	18 (1.8)	35.9	SH1875	Ø30 ~Ø254	14000
SBL-212	10.6	3300	3670 (36)	9690 (95)	18 (1.8)	56.6	SH2091	Ø35 ~Ø304	19300
SBL-215	10.6	2500	4790 (47)	12130 (119)	17 (1.7)	103.2	SH2511	Ø35 ~Ø381	

3-Jaw High Speed Hollow Power Chucks



>> Dimensions

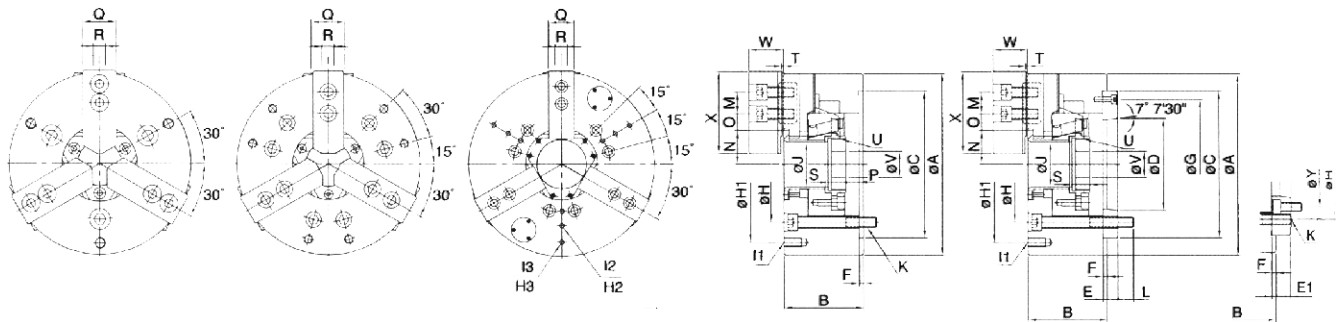

>> Specifications

Order Number	MODEL	Nose Of Spindle	A	B	C (h6)	D	E	E1	F	G	H	H1	I1	H2	I2	H3
701200	SB-204	--	110	59	85	--	--	--	4	--	70.6	--	--	--	--	--
701202	SB-205	A2-4	135	60	110	63.513	20	--	4	96	82.6	PCD0118	3-M8x1.25P	--	--	--
701204	SB-206	A2-5	169	81	140	82.563	15	--	5	116	104.8	PCD0145	6-M10x1.5P	--	--	--
701206	SB-208	A2-6(A2-5)	210	91	170	106.375	17	23	5	150	133.4	PCD0180	6-M10x1.5P	--	--	--
701208	SB-210	A2-8(A2-6)	254	100	220	139.719	18	28	5	190	171.4	PCD0225	6-M12x1.75P	--	--	--
701210	SB-212	A2-8	304	110	220	139.719	18	--	6	190	171.4	PCD0250	6-M12x1.75P	--	--	--
701202	SB-215	A2-11(A2-8)	381	133	300	196.869	22	33	6	260	235	--	--	PCD0230	3-M12x1.75P	PCD0300
701204	SB-218	A2-11(A2-8)	450	133	300	196.869	22	33	6	260	235	PCD0230	3-M12x1.75P	PCD0300	4-M10x1.75P	PCD0380
701206	SB-221	A2-15(A2-11)	530	140	380	285.775	27	41	6	330.2	330.2	PCD0300	3-M16x2P	PCD0380	3-M16x2P	PCD0460
701208	SB-224	A2-20(A2-15)	610	149	520	412.775	27	42	6	463.2	463.6	PCD0350	3-M16x2P	PCD0450	3-M16x2P	PCD0550

MODEL	I3	J	K	L	M	N max.	N min.	O max.	O min.	P max.	P min.	Q	R	S	T	U	V	W	X
SB-204	--	26	3-M10x1.5P	--	14	23	20.3	11.5	6.7	3.5	-6.5	23	10	17.5	2	M32x1.5P	12	24	49.5
SB-205	--	33	3-M10x1.5P	15	14	26.2	23.5	19	6	1	-9	25	10	20	2	M40x1.5P	12	31.5	62
SB-206	--	45	6-M10x1.5P	16	20	32.35	29.6	24	7	11	-1	31	12	19	2	M55x2P	20	37	73
SB-208	--	52	6-M12x1.75P	18	25	39.1	35.4	30	10	14.5	-1.5	35	14	20.5	2	M60x2P	30	39	95
SB-210	--	75	6-M16x2P	19	30	51.5	47.1	34	12	8.5	-10.5	40	16	25	2	M85x2P	40	43	110
SB-212	--	91	6-M16x2P	25	30	61.6	56.3	46	12	8	-15	50	21	28	2	M100x2P	50	51	129
SB-215	3-M12x1.75P	117.5	6-M20x2.5P	28	43	82.3	77	46	13	7.5	-16	62	22	42.5	5	M130x2P	48	66	165
SB-218	4-M10x1.75P	120	6-M20x2.5P	28	43	83.8	78.5	78	18	7.5	-16	62	22	42.5	5	M130x2P	48	66	165
SB-221	3-M16x2P	180	6-M24x3P	33	60	119.6	114.3	63.3	21.3	10.5	-13	65	25	42.5	5	M195x2P	80	73.5	180
SB-224	3-M16x2P	205	6-M24x3P	37	60	134.4	128.4	87.3	21.3	13.5	-11	65	25	42.5	5	M220x3P	80	73.5	180

MODEL	Y	Thru-Hole [Diameter] (mm)	Plunger Stroke (mm)	Jaw Stroke [Diameter] (mm)	Max.Speed r.p.m.(min-1)	Max.Pull Force kgf (KN)	Max.Gripping Force kgf (KN)	Max.Hydr. Pressure kgf/cm2(Mpa)	Weight (kg)	Matching Cylinder	Gripping Range	Price
SB-204	--	26	10	5.4	8000	1428 (14)	2850 (28)	24 (2.3)	3.8	SH1036	Ø7 ~Ø110	
SB-205	--	33	10	5.4	7000	1730 (17)	3570 (35)	29 (2.8)	6.1	SH1036	Ø10 ~Ø135	8000
SB-206	--	45	12	5.5	6000	2140 (21)	5710 (56)	28 (2.7)	12.5	SH1246	Ø13 ~Ø169	9000
SB-208	104.8	52	16	7.4	5000	3360 (33)	8360 (82)	26 (2.5)	21.9	SH1552	Ø13 ~Ø210	10000
SB-210	133.4	75	19	8.8	4200	4280 (42)	11010 (108)	27 (2.6)	33.7	SH1875	Ø30 ~Ø254	14000
SB-212	--	91	23	10.6	3300	5500 (54)	14380 (141)	27 (2.6)	55.3	SH2091	Ø35 ~Ø304	19300
SB-215	171.4	117.5	23	10.6	2500	7140 (70)	18250 (179)	24.5 (2.4)	106.8	SH2511	Ø35 ~Ø381	
SB-218	171.4	120	23	10.6	2000	7140 (70)	18250 (179)	24.5 (2.4)	152	SH2511	Ø40 ~Ø450	
SB-221	235	180	23	10.6	1700	9080 (89)	23760 (233)	31.5 (3.0)	195.2	SH2816	Ø115 ~Ø530	
SB-224	330.2	205	26	12	1400	9080 (89)	23760 (233)	31.5 (3.0)	169.4	SH2816	Ø140 ~Ø610	

4-Jaw High Speed Hollow Power Chucks



>> Dimensions

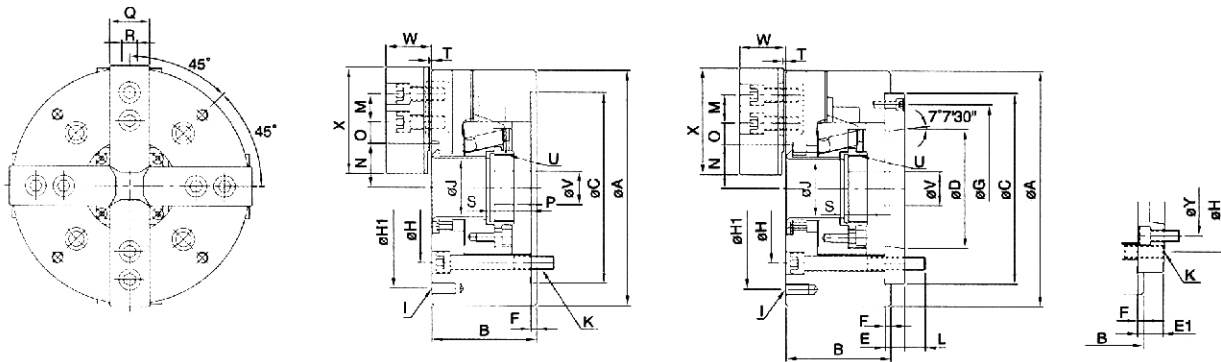

>> Specifications

Order Number	MODEL	Nose Of Spindle	A	B	C (h6)	D	E	E1	F	G	H	H1	I	J	K	L
701300	SBS-206	A2-5	169	81	140	82.563	15	--	5	116	104.8	PCDØ145	4-M10x1.5P	45	4-M10x1.5P	16
701302	SBS-208	A2-6(A2-5)	210	91	170	106.375	17	23	5	150	133.4	PCDØ180	4-M10x1.5P	52	4-M12x1.75P	18
701304	SBS-210	A2-8(A2-6)	254	100	220	139.719	18	28	5	190	171.4	PCDØ225	4-M12x1.75P	75	4-M16x2P	19
701306	SBS-212	A2-8	304	110	220	139.719	18	--	6	190	171.4	PCDØ250	4-M12x1.75P	91	4-M16x2P	25
701308	SBS-215	A2-11(A2-8)	381	133	300	196.869	22	33	6	260	235	PCDØ324	4-M12x1.75P	117.5	4-M20x2.5P	28

MODEL	M	N max.	N min.	O max.	O min.	P max.	P min.	Q	R	S	T	U	V	W	X	Y	Thru-Hole [Diameter] (mm)	Plunger Stroke (mm)
SBS-206	20	32.35	24	24	7	11	-1	31	12	19	2	M55x2P	20	37	73	--	45	12
SBS-208	25	39.1	30	30	10	14.5	-1.5	35	14	20.5	2	M60x2P	30	39	95	104.8	52	16
SBS-210	30	51.5	34	34	12	8.5	-10.5	40	16	25	2	M85x2P	40	43	110	133.4	75	19
SBS-212	30	61.6	46	46	12	8	-15	50	21	28	2	M100x2P	50	51	129	--	91	23
SBS-215	43	82.3	46	46	13	7.5	-15	62	22	42.5	2	M130x2P	48	66	165	171.4	117.5	23

MODEL	Jaw Stroke (Diameter) (mm)	Max.Speed r.p.m.(min-1)	Max.Pull Force kgf (KN)	Max.Gripping Force kgf (KN)	Max. Hydr. Pressure kgf/cm2 (Mpa)	Weight (kg)	Matching Cylinder	Gripping Range	Price
SBS-206	5.5	4500	1630 (16)	4180 (16)	21 (2.1)	14.2	SH1246	Ø22~Ø169	10600
SBS-208	7.4	3600	2440 (24)	6010 (24)	19 (1.9)	24.5	SH1552	Ø25~Ø210	12000
SBS-210	8.8	3200	3160 (31)	8050 (31)	20 (2.0)	38.1	SH1875	Ø28~Ø254	16000
SBS-212	10.6	2500	4080 (40)	10400 (40)	20 (2.0)	60..5	SH2091	Ø35~Ø304	21600
SBS-215	10.6	1800	5400 (53)	13600 (53)	19 (1.9)	111.5	SH2511	Ø63~Ø381	

Large Through Hole 3-Jaw High Speed Power Chuck

>> Dimensions

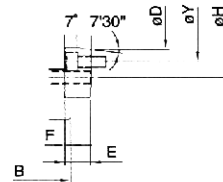
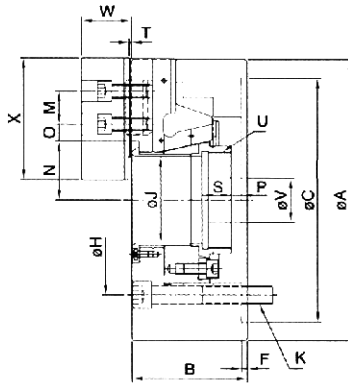
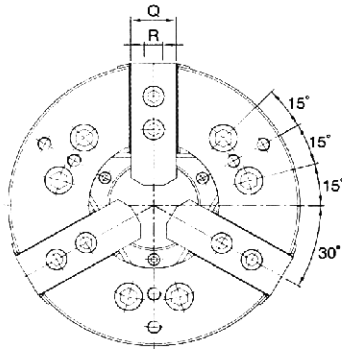

>> Specifications

Order Number	MODEL	Nose Of Spindle	A	B	C (h6)	D	E	F	H	J	K	M	N max.	N min.	O max.	O min.	P max.	P min.	Q	R	S	T	U
701500	SBB-206	A2-5	170	81	140	Ø82.563	20	5	PCDØ122	52	6-M10x1.5P	20	36.35	33.6	21.1	9.1	7	-5.1	31	12	23	2	M60x2P
701502	SBB-208	A2-6	215	91	170	Ø106.375	22	5	PCDØ150	66	6-M12x1.75P	25	46.6	42.9	26.6	11.6	10	-6.1	35	14	25	2	M75x2P
701504	SBB-210	A2-8	256	100	220	Ø139.719	28	5	PCDØ180	81	6-M16x2P	30	54.6	50.1	33.1	13.6	8.5	-10.1	40	16	25	2	M90x2P

MODEL	V	W	X	Y	Thru-Hole Diameter (mm)	Plunger Stroke (mm)	Jaw Stroke Diameter (mm)	Max. Speed r.p.m (min-1)	Max. Pull Force kgf (KN)	Max. Gripping Force kgf (KN)	Max. Hydr. kgf/cm2 (Mpa)	Weight (kg)	Matching Cylinder	Gripping Range	Price
SBB-206	20	37.5	73	104.8	52	12	5.5	6000	2200 (21.5)	5900 (58)	21 (2.1)	12.3	SH1452S	Ø13~Ø170	
SBB-208	30	39.5	80	133.4	66	16	7.4	5000	3400 (33)	8800 (86)	26 (2.5)	21.7	SH1666S	Ø50~Ø215	
SBB-210	40	43	110	171.4	81	19	8.8	4200	4300 (42)	11100 (109)	29 (2.8)	33.6	SH1881S	Ø34~Ø254	

Large Through Hole Super Thin Hollow Rotary Hydraulic Cylinder

>> Dimensions

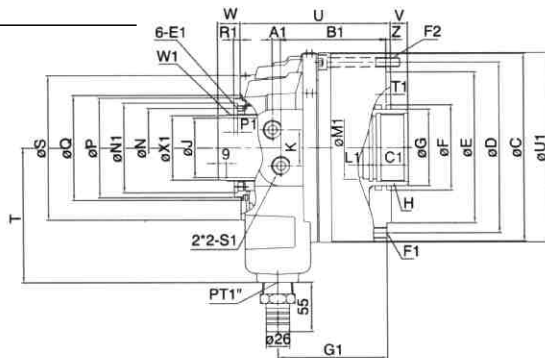
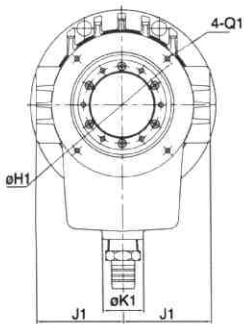

- Super thin & Lightweight:**
Super thin outer structure makes the weight lighter than the traditional rotary cylinders; meanwhile, the compactness and miniaturization lower the burden of machines.
- Large Thru-hole Diameter:**
With large open center, gripping range of Bar stock can be increased.
- Built-in Check Valve:**
With built-in "check valve", work pieces can be effectively prevented from flying out during abrupt failure of pressure

>> Specifications

Order Number	MODEL	A1	B1	C	C1	D	E	E1	F	F1	F2	G	G1	H	H1	J	J1	K	K1	L1	M1	N	N1	P	P1	Q	Q1	R1	S	S1	T	T1	U
701600	SH1452S	9	105.5	180	30	165	140	M6x1P	85	12-M10x1.5P	6-M8x1.25P	70	110.2	M60x2P	120	52	83	40	46	15	55	73	85	96	4	101.8	M6x1P	7.3	137	PT1/2	130	4	152
701602	SH1666S	9	116.5	209	35	190	168	M6x1P	95	12-M12x1.75P	6-M10x1.5P	85	121.2	M75x2P	145	66	99	40	46	15	70	88	100	111	4	116.8	M6x1P	7.3	161	PT1/2	150	5	166
701604	SH1881S	10	130.5	222	35	205	168	M6x1P	110	12-M12x1.75P	6-M10x1.5P	100	136	M90x2P	166	81	107.5	40	46	15	85	103	113	126	4	131.8	M6x1P	7.3	176	PT1/2	175	5	186

MODEL	U1	V max.	V min.	W max.	W1	W min.	X1	Z	Piston Stroke (mm)	Max. Speed r.p.m. (min)	Piston Dia (mm)	GD2 (kg.m ²)	Oil Leakage Rate (µmin)	Max. Pressure kgf/cm2 (Mpa)	Piston Area (cm ²) Push Side Pull Side	Max. Operating Force Push Side Pull Side kgf (KN)	Weight (kg)	Price
SH1452S	183	17	-3	45	M58x1.5P	25	55.8	5	20	6500	145	0.035	3.9	40 (3.9)	135 124	4860 (7.6) 4464 (43.7)	12.3	
SH1666S	211	19	-3	47	M74x1.5P	25	71.8	5	22	5600	165	0.07	4	40 (3.9)	168 155	6048 (59.3) 5580 (54.7)	17.4	
SH1881S	226	21	-4	50	M89x2P	25	85.8	5	25	4800	180	0.09	4.3	40 (3.9)	189 174	6804 (66.7) 6264 (61.4)	21.9	

Super High Speed Hollow Rotary Hydraulic Cylinders



>> Dimensions

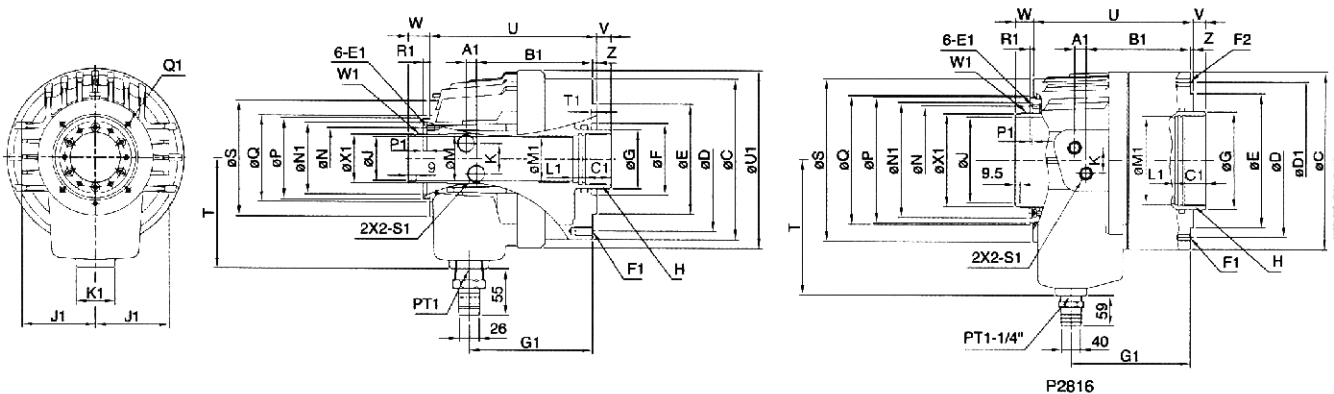

>> Specifications

Order Number	MODEL	A1	B1	C	C1	D	D1	E (h7)	E1	F	F1	F12	G	G1	H	J	J1	K	K1	L1
701400	SH0928	9	109	120	25	100	--	80	8-M5x0.8P	60	6-M8x1.25P	--	45	114	M38x1.5P	28	60	25	46	15
701402	SH1036	11	120	136	25	115	--	100	6-M5x0.8P	65	6-M10x1.5P	--	48	126	M42x1.5P	36	68	32	46	15
701404	SH1246	12	126.5	155	30	130	--	100	6-M6x1P	80	12-M10x1.5P	--	65	134	M55x2P	46	76	36	46	15
701406	SH1552	12	136	190	30	170	--	130	6-M6x1P	85	12-M10x1.5P	--	70	145	M60x2P	52	87.5	36	46	15
701408	SH1875	17.5	154.5	215	35	190	--	160	6-M6x1P	125	12-M10x1.5P	--	95	162	M85x2P	75	101	36	46	15
701410	SH2091	21	168	240	35	215	--	180	6-M6x1P	140	12-M12x1.75P	--	110	183	M100x2P	91	110	36	46	15
701412	SH2511	27	191	310	45	275	--	230	6-M6x1P	166	12-M16x2P	--	140	218	M130x2P	117.5	135	40	46	15
701414	SH2816	22	201	345	45	298	305	260	6-M8x1.25P	--	12-M12x1.75P	12-M16x2P	190	229	M175x3P	166.5	180	50	60	15

MODEL	M	M1	N	N1	P	P1	Q	Q1	R1	S	S1	T	T1	U	U1	V max.	v min.	W max.	W1	W min.	X1
SH0928	34.6	34	44	53	59	4	64.8	4-M4x0.7P(PCDØ76)	5	95	PT/4	105	4	159	137	9.05	-0.95	33.95	M34x1.5P	23.95	31.8
SH1036	44.6	38	55	64	73	6	80	4-M5x0.8P(PCDØ88)	5	105	PT3/8	115	6	179	154	10	-5	39	M44x1.5P	24	42
SH1246	52.9	50	64	76	85	4	90	4-M5x0.8P(PCDØ98)	6	116	PT1/2	115	6	184	172	10	-5	40	M52x1.5P	25	50
SH1552	59.6	55	73	85	96	4	102	4-M6x1P(PCDØ110)	7	135	PT1/2	130	6	196	210	17	-5	47	M58x1.5P	25	56
SH1875	84.6	80	98	108	121	4	131	4-M6x1P(PCDØ155)	7	164	PT1/2	160	4	230	235	20	-5	50	M84x2P	25	81
SH2091	99.6	95	108	120	138	4	147	4-M6x1P(PCDØ165)	7	180	PT1/2	185	6	253	260	25	-5	55	M99x2P	25	96
SH2511	134.6	125	148	160	178	5	184	4-M6x1P(PCDØ206)	7	230	PT1/2	210	7	304	302	24	-6	55	M134x2P	25	130
SH2816	185	171.5	210	224	244	5	250	6-M6x1P(PCDØ275)	7	316	PT3/4	262.5	--	308	--	24	-6	65	M185x3P	35	180

MODEL	Z	Piston Stroke (min)	Max. Speed r.p.m.(min-1)	Piston Dia.(mm)	GD2 (kg.m2)	Oil Leakage Rate (l/min)	Max. Pressure (kgf/cm2)(Mpa)	Piston Area(cm2)		Max. Operating Force		Weight (kg)	Price
								Push Side	Push Side	Push Side (KN)	Pull Side (KN)		
SH0928	5	10	8000	90	0.008	3.0	40 (3.9)	54	47.5	2000 (19.6)	1750 (17.2)		
SH1036	5	15	8000	105	0.012	3.0	40 (3.9)	70	68	2500 (24.5)	2400 (23.5)	9.0	5600
SH1246	5	15	7000	125	0.019	3.0	40 (3.9)	100	89	3700 (36.2)	3200 (31.3)	11.9	6300
SH1552	5	22	6200	155	0.053	3.9	40 (3.9)	160	150	5900 (57.8)	5500 (53.9)	17.3	7300
SH1875	5	25	4700	180	0.096	4.2	40 (3.9)	198	183	7200 (70.5)	6700 (65.6)	26.4	8500
SH2091	5	30	3800	205	0.16	4.5	40 (3.9)	252	235	9200 (90.1)	8600 (84.3)	37.1	
SH2511	6	30	2800	250	0.5	7.0	40 (3.9)	348	336	12400 (121.5)	12000 (117.6)	63.0	
SH2816	6	30	2000	280	3.5	8.4	40 (3.9)	346	332	12200 (119.6)	11800 (115.7)	--	

Pull Back Power Chucks



>> Dimensions

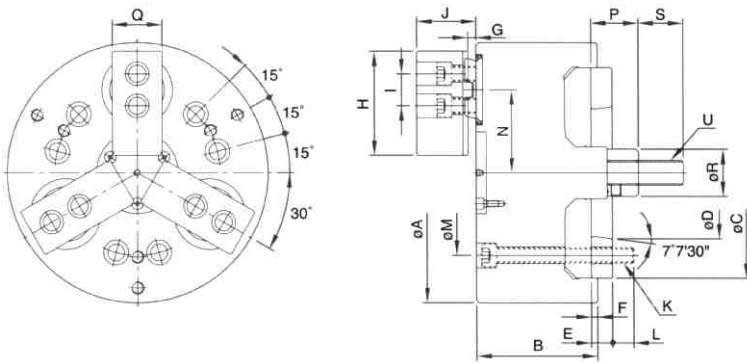

Pull back feature of radial gripping will lead to almost no work piece uplifting displacement; Pull Back Power Chucks are ideal for machining casting and forging parts;

1. By appressing the gripped work piece to the surface, Pull Back Power Chucks are suitable for heavy machining.
2. Chuck Actuators with cylindrical structure are durable and ensures high gripping repeatability.
3. Accurate self-centering and pull back features are adequate for precise length control machining requirements.
4. Optional components can be selected for detecting the right position on an automated loading machine.

>> Specifications

Order Number	MODEL	A	B	C	D	E	F	G max.	G min.	H	J max.	J min.
701700	SPL-06	169	83	140	82.563	15	5	15	5	70	46	36
701702	SPL-08	210	97	170	106.375	17	5	16.5	6.5	84	57	47
701704	SPL-10	254	110	220	139.719	18	5	22	6	100	68	52
701706	SPL-12	304	125	220	139.719	18	5	21.5	5.5	120	72.5	56.5

MODEL	I	K	L	M	N max.	N min.	P max.	P min.	Q	R
SPL-06		6-M10x1.5P	14	104.8	56.65	54	33	23	35	32
SPL-08	26	6-M12x1.75P	17	133.4	69.65	67	38	28	40	38
SPL-10	32	6-M16x2P	24	171.4	87.8	82	48	32	50	50
SPL-12	36	6-M16x2P	20	171.4	102.8	97	47	31	60	52

MODEL	S	U	Plunger Stroke (mm)	Jaw Stoke [Diameter](mm)	Max.Speed r.p.m(min-1)	Max.Pull Force kgf (KN)
SPL-06	36	M16x2P	10	5.3	3500	1326 (13)
SPL-08	36	M20x2.5P	10	5.3	3000	2142 (21)
SPL-10	46	M24x3P	16	11.6	2500	3060 (30)
SPL-12	50	M27x3P	16	11.6	2000	4386 (43)

MODEL	Max. Gripping Force kgf (KN)	Max. Hydr. kgf/cm ² (Mpa)	Weight (kg)	Matching Cylinder	Girpping Pange	Price
SPL-06	2958 (29)	22 (2.2)	13.8	J-Y1020	ø35~ø160	
SPL-08	4896 (48)	22 (2.2)	27.8	J-Y1225	ø40~ø210	
SPL-10	4998 (49)	30 (2.9)	45.9	J-Y1225	ø50~ø254	
SPL-12	7242 (71)	30 (2.9)	75.7	J-Y1530	ø50~ø304	

2-JAW Solid Power Chucks



>> Dimensions

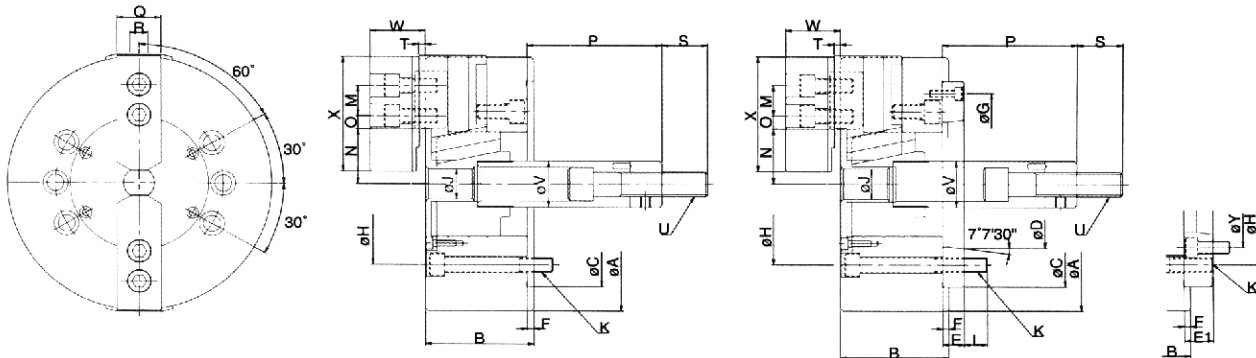

>> Specifications

Order Number	MODEL	Nose Of Spindle	A	B	C (h6)	D	E	E1	F	G	H	J
702100	JNL-06	A2-5	165	74	140	82.563	15	--	5	116	104.8	21
702102	JNL-08	A2-6(A2-5)	210	85	170	106.375	17	23	5	150	133.4	25
702104	JNL-10	A2-8(A2-6)	254	89	220	139.719	18	28	5	190	171.4	34
702106	JNL-12	A2-8	304	106	220	139.719	18	--	6	190	171.4	34

MODEL	K	L	M	N max.	N min.	O max.	O min.	P max.	P min.	Q	R	S
JNL-06	6-M10x1.5P	14	20	37.8	33.25	15.1	9.1	101.5	81.5	31	12	36
JNL-08	6-M12x1.75P	18	25	46.3	41.9	22.1	10.1	127	106	35	14	36
JNL-10	6-M16x2P	25	30	51.4	47	30.6	9.6	158	133	40	16	36
JNL-12	6-M16x2P	25	30	60.7	55.45	48.6	12.6	163	133	50	18	36

MODEL	T	U	V	W	X	Y	Plunger Stroke (mm)	Jaw Stroke [Diameter](mm)	Max.Speed r.p.m(min-1)
JNL-06	4	M16x2P	34	39	73	--	20	8.5	5000
JNL-08	5	M20x2.5P	38	42	95	104.8	21	8.8	4000
JNL-10	5	M20x2.5P	45	46	110	133.4	25	8.8	3500
JNL-12	5	M20x2.5P	50	54	129	--	30	10.5	3000

MODEL	Max. Pull Force (kgf)	Max. Pull Force (KN)	Max. Gripping Force (kgf)	Max. Gripping Force (KN)	Max. Hydr. (kgf/cm2)	Max. Hydr. (Mpa)	Weight (kg)	Matching Cylinder	Girpping Pange	Price
JNL-06	1220	(12)	3460	(34)	17	(1.7)	11.1	J-Y1020(JL1020R)	Ø9~Ø165	8300
JNL-08	1630	(16)	4990	(49)	16	(1.6)	21.3	J-Y1225(JL1225R)	Ø12~Ø210	9000
JNL-10	1930	(19)	7140	(70)	19	(1.9)	32.6	J-Y1225(JL1225R)	Ø15~Ø254	12000
JNL-12	2750	(27)	10300	(101)	20	(2.0)	57.0	J-Y1530(JL1530R)	Ø20~Ø304	17300

3-JAW Solid Power Chucks



>> Dimensions

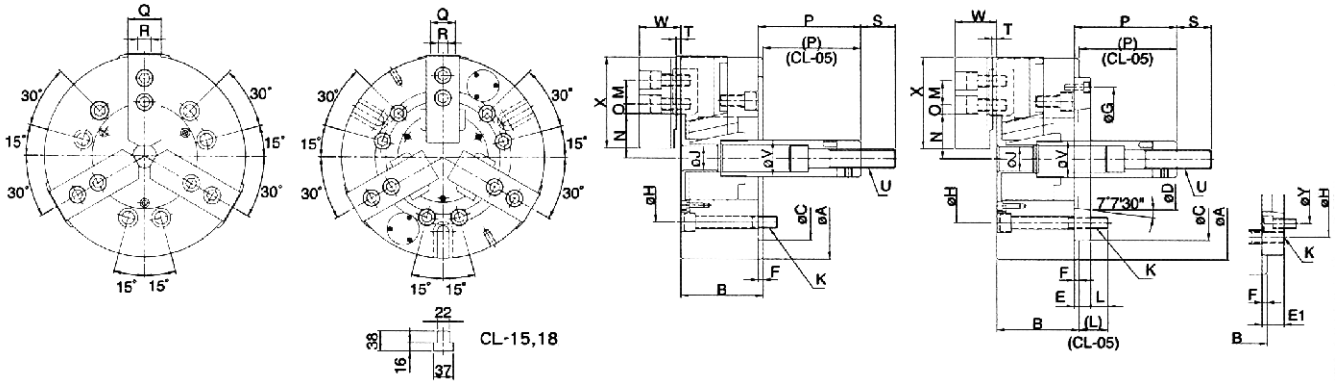

>> Specifications

Order Number	MODEL	Nose Of Spindle	A	B	C (h6)	D	E	E1	F	G	H	J	K	L	M
702200	JN-05	A2-4	135	55	80	63.513	--	--	7	--	100	--	3-M8x1.25P	14	14
702202	JN-06	A2-5	165	74	140	82.563	15	--	5	116	104.8	21	6-M10x1.5P	14	20
702204	JN-08	A2-6(A2-5)	210	85	170	106.375	17	23	5	150	133.4	25	6-M12x1.75P	18	25
702206	JN-10	A2-8(A2-6)	254	89	220	139.719	18	28	5	190	171.4	34	6-M16x2P	25	30
702208	JN-12	A2-8	304	106	220	139.719	18	--	6	190	171.4	34	6-M16x2P	25	30
702210	JN-15	A2-11	381	114	300	196.869	22	--	6	260	235	--	6-M20x2.5P	32	43
702212	JN-18	A2-11	450	114	300	196.869	22	--	6	260	235	--	6-M20x2.5P	32	43

MODEL	N max.	N min.	O max.	O min.	P max.	P min.	Q	R	S	T	U	V	W	X	Y
JN-05	30.4	27.2	17.1	9.6	9	-6	25	10	35	2	M12x1.75P	28	31	62	--
JN-06	37.8	33.25	15.1	9.1	101.5	81.5	31	12	36	4	M16x2P	34	39	73	--
JN-08	46.3	41.9	22.1	10.1	127	106	35	14	36	5	M20x2.5P	38	42	95	104.8
JN-10	51.4	47	30.6	9.6	158	133	40	16	36	5	M20x2.5P	45	46	110	133.4
JN-12	60.7	55.45	48.6	12.6	163	133	50	18	36	5	M20x2.5P	50	54	129	--
JN-15	69.05	60.97	58.05	40.05	104	69	62	25.5	55	7	M30x3.5P	60	68	165	--
JN-18	99.46	91.38	58.05	40.05	92	57	62	25.5	55	7	M30x3.5P	60	68	165	--

MODEL	Plunger Stroke (mm)	Jaw Stroke [Diameter] (mm)	Max. Speed r.p.m (min-1)	Max. Pull Force kgf (KN)	最大静夹力 Max. Hydr.Pressure (kgf/cm ² (Mpa)	Max. Hydr.Pressure kgf/cm ² (Mpa)	Weight (kg)	Matching Cylinder	Gripping Range	Price
JN-05	15	6.4	5500	800 (7.8)	25 (2.5)	25 (2.5)	6	J-Y0815	Ø8~Ø135	7400
JN-06	20	8.5	5000	1730 (17)	25 (2.5)	25 (2.5)	11.4	J-Y1020(JL1020R)	Ø18~Ø165	8000
JN-08	21	8.8	4600	2440 (24)	25 (2.5)	25 (2.5)	21.9	J-Y1225(JL1225R)	Ø12~Ø210	9000
JN-10	25	8.8	4000	2850 (28)	29 (2.8)	29 (2.8)	33.4	J-Y1225(JL1225R)	Ø16~Ø254	12600
JN-12	30	10.5	3200	4080 (40)	29 (2.8)	29 (2.8)	58.5	J-Y1530(JL1530R)	Ø18~Ø304	17300
JN-15	35	16	3000	8260 (81)	32 (3.1)	32 (3.1)	100.6	J-Y2035(JL2035R)	Ø68~Ø381	
JN-18	35	16	2700	8260 (81)	32 (3.1)	32 (3.1)	134.3	J-Y2035(JL2035R)	Ø100~Ø450	

Solid Rotary Hydraulic Cylinder

>> Dimensions

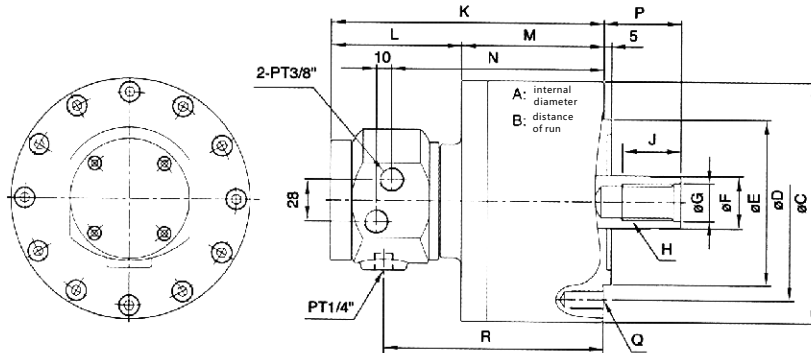

>> Specifications

Order Number	MODEL	A	B	C	D	E(h7)	F	G(H8)	H	J	K	L
702300	J-Y0815	75	15	115	90	65	30	21	M20×2.5P	35	137	72
702302	J-Y1020	105	20	135	100	80	30	21	M20×2.5P	35	155	72
702304	J-Y1225	125	25	160	130	110	35	25	M24×3P	45	163	72
702306	J-Y1530	150	30	190	130	110	45	31	M30×3.5P	45	173	72
702308	J-Y2035	200	35	245	145	120	55	37	M36×4P	60	191.5	72

MODEL	M	N	P max.	P min	Q	R	Piston Stroke (mm)	Max.Speed r.p.m. (min)
J-Y0815	65	97	46	31	6-M8×1.25P	102	15	6000
J-Y1020	83	115	45	25	6-M10×1.5P	120	20	5500
J-Y1225	91	123	51	26	6-M12×1.75P	128	25	5500
J-Y1530	101	133	56	26	12-M12×1.75P	138	30	4000
J-Y2035	119.5	151.5	69	34	12-M16×2P	156.5	35	4000

MODEL	GD ₂ (kg.m ²)	Oil Leakage Rate (l/min)	Max. Pressure kgf/cm ² (Mpa)		Piston Area(cm ²) Push Side Pull Side		Max. Operating Force kgf (KN)		Weight (kg)	Price
J-Y0815	0.01	0.8	40	(3.9)	43.5	36.5	1600	(15.7)	4.2	1850
J-Y1020	0.04	0.8	40	(3.9)	85.5	78.5	3200	(31.4)	5.9	2150
J-Y1225	0.09	0.8	40	(3.9)	121.5	112	4600	(43.7)	8.1	2500
J-Y1530	0.19	0.8	40	(3.9)	175.5	159.5	6500	(63.7)	11.9	2500
J-Y2035	0.39	0.8	40	(3.9)	312.5	288.5	11800	(115.6)	21.4	3300

Solid Rotary Hydraulic Cylinder (Built-in Check Valve)

1. Super thin structure:

Super thin outer structure reduces the interference with machines and lowers the burden of machines

2. Built-in Check Valve:

With built-in "check valve", work pieces can be effectively prevented from flying out during abrupt failure of pressure.



>> Dimensions

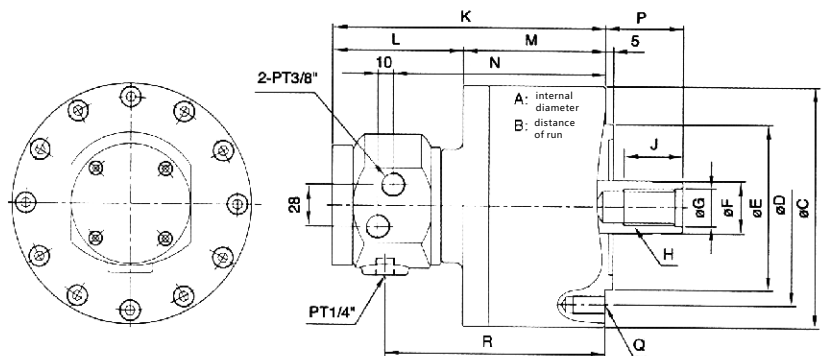

>> Specifications

Order Number	MODEL	A	B	C	D	E (h7)	F	G (H8)	H	J	K	L
702400	JL1020R	105	20	135	100	80	30	21	M20x2.5P	35	172	86
702402	JL1225R	125	25	160	130	110	35	25	M24x3P	45	180	86
702404	JL1530R	150	30	190	130	110	45	31	M30x3.5P	45	189	84
702406	JL2035R	200	35	245	145	120	55	37	M36x4P	60	206.5	83

MODEL	M	N	P max.	P min.	Q	R	Piston Stroke (mm)	Max. Speed r.p.m.(min-1)
JL1020R	86	132	45	25	6-M10x1.5P	137	20	6000
JL1225R	94	140	51	26	6-M12x1.75P	145	25	6000
JL1530R	105	149	56	26	12-M12x1.75P	154	30	5500
JL2035R	123.5	166.5	69	34	12-M16x2P	171.5	35	5500

MODEL	GD2 (kg.m2)	Oil Leakage Rate (/min)	Max. Pressure		Piston Area(cm2)		Max. Push Force		Weiht (kg)	Price
			kgf/cm2	(Mpa)	Push Side	Pull Side	kgf	(Kn)		
JL1020R	0.013	0.8	40	(3.9)	86	79	3200	(31.4)	6.6	
JL1225R	0.023	0.8	40	(3.9)	122	113	4600	(45.1)	8.8	
JL1530R	0.048	0.8	40	(3.9)	176	160	6500	(63.7)	12.8	
JL2035R	0.098	0.8	40	(3.9)	314	290	11800	(115.6)	22.5	

2ACTUATING AXES SELF-CENTERING SOLID AIR CHUCK FIXTURES

2 actuating axes self-centering solid air chuck fixtures is great for machining center. Two pairs of jaws clamp one after another to assure a workpiece to be locked completely.



>> Dimensions

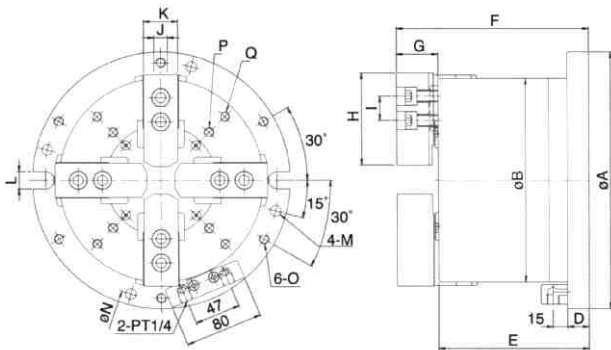

1. Rust-proof for Pneumatic Cylinder:

Inside wall of cylinder being rustproof treated; cylinder can work under wet or high moisture circumstances without rusty or seized trouble.

2. Dusts-proof and Waterproof:

Dust-proof and Waterproof structure prevents work-chips and coolant water from entering into inside of chuck cylinder to maintain its accuracy and lead to longer service life.

3. 4-jaw Clamping and Self-centering:

4-jaw clamping are steadier for machining. Two pairs of jaws are moved independently to assure complete lock and self-centering.

>> Operation Example

Speed, Accurate, Automatic

4-jaws clamping and self-center

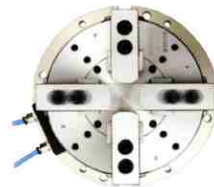

Piston "A" Clamping

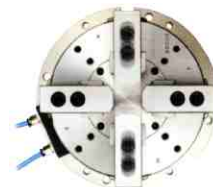

Piston "B" Clamping

>> Specifications

Order Number	MODEL	A	B	D	E	F	G	H	I	J	K	L	M	N
703100	JMA-06	224	175	20	130	170	40	73	20	12	31	18	11	Ø202
703102	JMA-08	265	210	22	154	196	42	95	25	14	35	18	11	Ø243
703104	JMA-10	315	250	25	176	222	46	110	30	16	40	18	13	Ø285

MODEL	O	P	Q	Apiston Area(cm2)	
				Push Side	Pull Side
JMA-06	M10×1.5P(PCD Ø202)	4-M8×1.25P(PCD Ø124)	4-M8×1.25P(PCD Ø156)	127	108
JMA-08	M10×1.5P(PCD Ø243)	4-M10×1.5P(PCD Ø140)	4-M10×1.5P(PCD Ø186)	184	157
JMA-10	M12×1.75P(PCD Ø285)	4-M10×1.5P(PCD Ø176)	4-M10×1.5P(PCD Ø224)	270	239

MODEL	Bpiston Area(cm2)		Plunger Stroke (mm)	Jaw Stoke [Diameter](mm)	Gripping Force At Air Pressure 7kgf/ cm ² (0.37Mpa)		Weight (kg)	Girpping Pange	Price
	Push Side	Pull Side			kgf	(KN)			
JMA-06	122	117	12	5.5	4500	(44)	24.8	Ø25~Ø175	
JMA-08	176	169	16	7.4	6400	(63)	41.3	Ø30~Ø210	
JMA-10	254	241	19	8.8	95	(93)	65.6	Ø35~Ø250	

2/3-JAW Hollow Power Chuck Fixtures

with built-in type cylinder, it is ideal for machining application on working table.

1. Rust-proof for cylinder :
being rustproof treated;
cylinder can work under wet or high moisture circumstances without rusty or seized trouble.

2. Dusts-proof and waterproof :
structure prevents
work-chips and coolant water from entering into
inside of chuck cylinder to maintain its accuracy
and lead to longer service life.

3. Benefit of Built-in Cylinder:
The cylinder is connected to chuck itself directly
for obtaining better stability, less space, and higher
machining efficiency



>> Dimensions

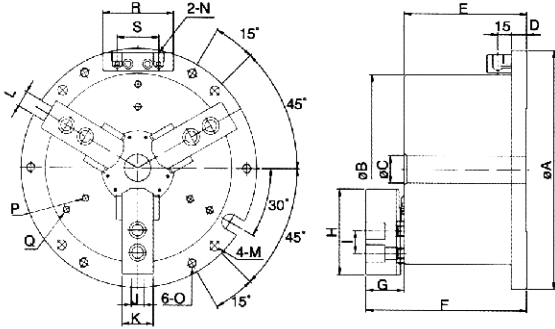

>> 2-JAW Specifications

Order Number	MODEL	A	B	C	D	E	F	G	H	I	J	K	L	M	N	O	P	R	S
703200	JMOT-04	155	115	--	15	77.5	103.5	26	49.5	14	10	23	13	Ø9(PCDØ135)	PT1/8	M8x1.25P		64	47
703202	JMOT-05	185	135	--	15	95	128	33	62	14	10	25	13	Ø9(PCDØ165)	PT1/4	M8x1.25P	3-M8x1.25P(PCDØ100)	80	47
703204	JMOT-06	224	169	25	16	118	158	40	73	20	12	31	18	Ø11(PCDØ202)	PT1/4	M10x1.5P	3-M8x1.25P(PCDØ134)	80	47
703206	JMOT-08	265	210	30	20	138	180	42	95	25	14	35	18	Ø11(PCDØ243)	PT1/4	M10x1.5P	3-M10x1.5P(PCDØ136)	80	47
703208	JMOT-10	315	254	52	23	150	196	46	110	30	16	40	18	Ø13(PCDØ285)	PT1/4	M12x1.75P	3-M12x1.75P(PCDØ170)	80	47

>> Operation Example

Examples of Attaching
Pneumatic Manual
Switch/Optional Accessories



Split type hand control valve



Adherent type hand control valve

MODEL	Q	Piston Area (cm ²)	Plunger Stroke (mm)	Jaw Stroke (Diameter) (mm)	Max. Gripping Force (kgf) (KN)	Max. Hydr. Pressure (kgf/cm ²) (Mpa)	Gripping Force At Air Pressure 7kgf/cm ² (0.7Mpa) (kgf) (KN)	Weight (kg)	Gripping Range	Price
JMOT-04	--	57	9	3.8	1900 (18.6)	12 (1.2)	1100 (10.8)	6.9	Ø9~Ø115	
JMOT-05	--	74	10	5.4	2620 (25.6)	16 (1.6)	1300 (12.7)	11.2	Ø12~Ø135	
JMOT-06	--	97	12	5.5	4030 (39.5)	16 (1.6)	2000 (19.6)	21.0	Ø15~Ø169	
JMOT-08	3-M10x1.5P(PCDØ186)	156	16	7.4	6480 (63.5)	16 (1.6)	3300 (32.3)	36.8	Ø20~Ø210	
JMOT-10	3-M12x1.75P(PCDØ230)	235	19	8.8	9760 (95.6)	16 (1.6)	4800 (47.0)	56.4	Ø33~Ø254	

>> 3-JAW Specifications

Order Number	MODEL	A	B	C	D	E	F	G	H	I	J	K	L	M	N	O	P	R	S
703300	JMO-04	157	115	--	15	77.5	104	26	49.5	14	10	23	13	Ø9(PCDØ135)	PT1/8	M8x1.25P		64	47
703302	JMO-05	185	135	--	15	95	128	33	62	14	10	25	13	Ø9(PCDØ165)	PT1/4	M8x1.25P	3-M8x1.25P(PCDØ100)	80	47
703304	JMO-06	224	169	25	16	118	158	40	73	20	12	31	18	Ø11(PCDØ202)	PT1/4	M10x1.5P	3-M8x1.25P(PCDØ134)	80	47
703306	JMO-08	265	210	30	20	138	180	42	95	25	14	35	18	Ø11(PCDØ243)	PT1/4	M10x1.5P	3-M10x1.5P(PCDØ136)	80	47
703308	JMO-10	315	254	52	23	150	196	46	110	30	16	40	18	Ø13(PCDØ285)	PT1/4	M12x1.75P	3-M12x1.75P(PCDØ170)	80	47
703310	JMO-12	375	304	80	23	165	219	54	129	30	21	50	18	Ø17(PCDØ340)	PT3/8	M16x2P	3-M12x1.75P(PCDØ200)	80	55

MODEL	Q	Piston Area (cm ²)	Plunger Stroke (mm)	Jaw Stroke (Diameter) (mm)	Max. Gripping Force (kgf) (KN)	Max. Hydr. Pressure (kgf/cm ²) (Mpa)	Gripping Force At Air Pressure 7kgf/cm ² (0.7Mpa) (kgf) (KN)	Weight (kg)	Gripping Range	Price
JMO-04	--	57	9	3.8	2400 (23.5)	15 (1.5)	1100 (10.8)	7.05	Ø9~Ø115	
JMO-05	--	74	10	5.4	3285 (32.2)	20 (2.0)	1300 (12.7)	11.2	Ø12~Ø135	
JMO-06	--	97	12	5.5	5040 (49.4)	20 (2.0)	2000 (19.6)	21.0	Ø15~Ø169	
JMO-08	3-M10x1.5P(PCDØ186)	156	16	7.4	8100 (79.4)	20 (2.0)	3300 (32.3)	36.8	Ø20~Ø210	
JMO-10	3-M12x1.75P(PCDØ230)	235	19	8.8	12210 (119.7)	20 (2.0)	4800 (47.0)	56.4	Ø33~Ø254	
JMO-12	3-M12x1.75P(PCDØ260)	292	23	10.6	14500 (142.1)	20 (2.0)	5100 (50.0)	88.5	Ø40~Ø304	

2-JAW SUPER PRECISION AIR CHUCK FIXTURES



>> Dimensions

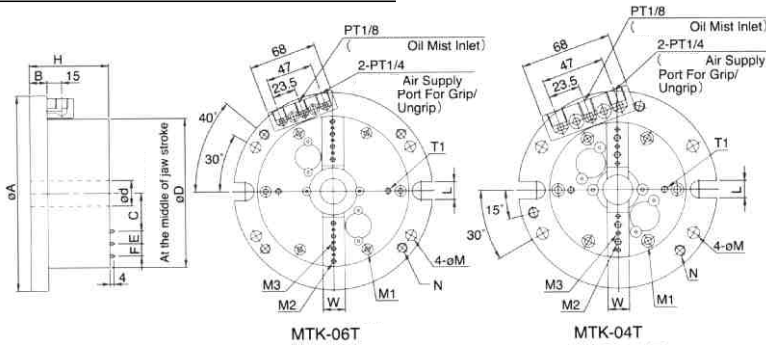

1. Pre-machined tapped holes and lubrication path:

There are tapped holes for fixing jigs, thus, additional screw machining is not necessary, and pre-machined lubrications path can connect to auto-lubrication unit to lubricate the chuck automatically.

2. Built-in Cylinder:

Connect cylinder directly to the chuck for stable gripping.

3. Precise soft jaw positioning:

It's easy to remount soft jaw to the correct position with dowel pins on it.

4. High gripping precision brings better quality and efficiency.

Good coaxiality and repeatability of gripping are able to achieve the accuracy of μ degree machining processes can be simplified or shortened to make high precision machining with high efficiency come true.

>> Specifications

Order Number	MODEL	A	B	C	D	d(h7)	E	F	H	W	L	M	M1	M2	M3
703400	JMTKL-04T	146	17	20.75	101.6	18	12.7	12.7	80	16	13	Ø09(PCD Ø130)	6-M5×0.8P(PCD Ø88.9)	4-M5×0.8P	6-Ø3.18
703402	JMTKL-06T	200	18	39.75	152.4	26	12.7	12.7	81	22	18	Ø11(PCD Ø180)	6-M6×1P(PCD Ø135.89)	8-M5×0.8P	6-Ø3.18

MODEL	N	T1	T.I.R Jaw T.I.R	Jaw Stroke (Diameter) (mm)	Repeatability	Gripping Force At Air 7kgf/cm ² Pressre (0.7Mpa) kgf (KN)	Weight (kg)	Price
JMTKL-04T	3-M8×1.25P	2-M5×0.8P(PCDØ70)	0.001	3	0.001	310 (3.1)	6	
JMTKL-06T	4-M10×1.5P	2-M6×1P(PCDØ110)	0.001	3	0.001	790 (7.8)	12.6	

3-JAW SUPER PRECISION AIR CHUCK FIXTURES

>> Dimensions

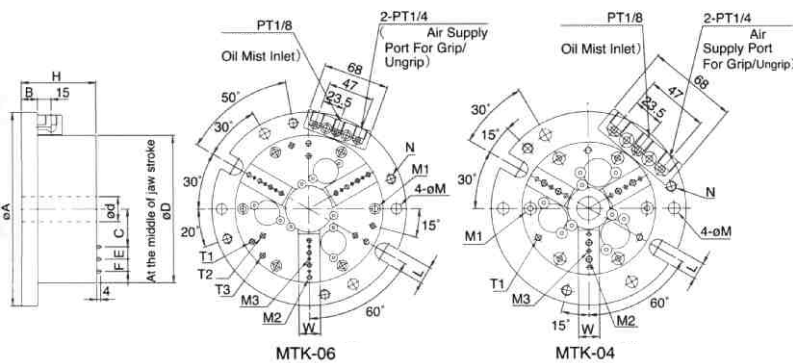

Split type hand control valve

This product reaches the repeatability of " μ degree"

>> Operation Example

Examples of Attaching Pneumatic Manual Switch /Optional Accessories

Order Number	MODEL	A	B	C	D	d(h7)	E	F	H	W	L	M	M1	M2	M3	N
703500	JMTK-04T	148	17	20.75	101.6	18	12.7	12.7	80	16	13	Ø09(PCD Ø130)	6-M5×0.8P(PCD Ø88.9)	6-M5×0.8P	9-Ø3.18	3-M8×1.25P
703502	JMTK-06T	200	18	39.75	152.4	26	12.7	12.7	81	22	18	Ø11(PCD Ø180)	6-M6×1P(PCD Ø135.89)	12-M5×0.8P	9-Ø3.18	4-M10×1.5P

MODEL	T1	T2	T3	T.I.R Jaw T.I.R	Jaw Stroke (Diameter) (mm)	Repeatability	Gripping Force At Air 7kgf/cm ² Pressre (0.7Mpa) kgf (KN)	Weight (kg)	Price
JMTK-04T	3-M5×0.8P(PCDØ88.9)			0.001	3	0.001	310 (3.1)	6.2	
JMTK-06T	3-M6×1P(PCDØ135.89)	3-M6×1P(PCDØ110)	3-M6×1P(PCDØ135.89)	0.001	3	0.001	790 (7.8)	13	

2-JAW SUPER PRECISION AIR CHUCK

>> Operation Example

>> Dimensions

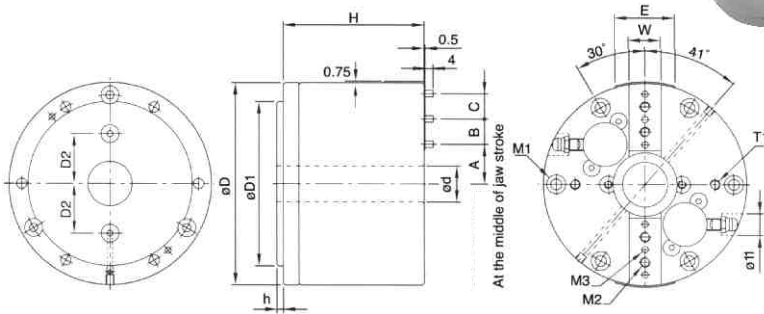

1.Pre-machined tapped holes and lubrication path:

There are tapped holes for fixing jigs, thus, additional screw machining is not necessary, and pre-machined lubrications path can connect to auto-lubrication unit to lubricate the chuck automatically.

2.Built-in Cylinder:

Connect cylinder directly to the chuck for stable gripping.

3.Precise soft jaw positioning:

It's easy to remount soft jaw to the correct position with dowel pins on it.

4.High gripping precision brings better quality and efficiency.

Good coaxiality and repeatability of gripping are able to achieve the accuracy of μ degree machining processes can be simplified or shortened to make high precision machining with high efficiency come true.

>> Specifications

Order Number	MODEL	A	B	C	D	E	D1	d (H7)	D2	H	h	M1	M2
703600	JTKL-04T	20.75	12.7	12.7	101.6	30	82.55	18	25	70.3	3.2	6-M5×0.8P(PCD Ø88.9)	4-M5×0.8P
703602	JTKL-06T	39.75	12.7	12.7	152.4	40	124.97	26	34.5	70.3	3.2	6-M6×1P(PCD Ø135.89)	8-M5×0.8P
703604	JTKL-08T	65.75	25.4	-	203.2	45	167.64	50	50	99.5	7.0	6-M10×1.5P(PCD Ø182.88)	4-M10×1.5P

MODEL	M3	W	T1	μ T.I.R Jaw T.I.R	Jaw Stroke (Diameter) (mm)	Repeatability	Gripping Force At Air Pressure kgf (0.7Mpa) (KN)	Max. Speed r.p.m(min ⁻¹)	Weight (kg)	Price
JTKL-04T	6-Ø3.18	16	2-M5×0.8P(PCDØ70)	0.001	3	0.001	310 (3.1)	3500	4.2	
JTKL-06T	6-Ø3.18	22	2-M6×1P(PCDØ110)	0.001	3	0.001	790 (7.8)	3500	9.5	
JTKL-08T	4-Ø6.36	25	2-M8×1.25P(PCDØ150)	0.001	3	0.001	1450 (14.3)	3000	25.1	

3-JAW SUPER PRECISION AIR CHUCK

>> Operation Example

>> Dimensions

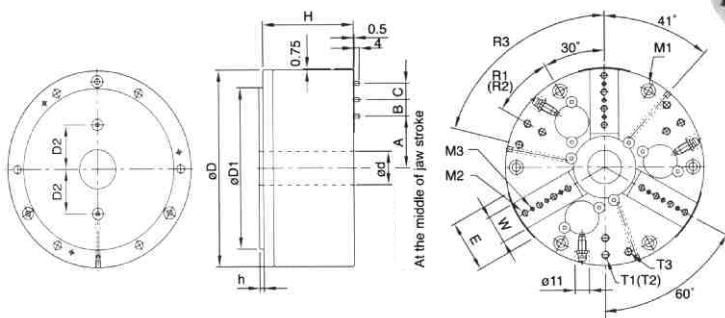

This product reaches the repeatability of " μ degree"

Order Number	MODEL	A	B	C	D	E	D1	d (H7)	D2	H	h	W	M1	M2	M3	T1
703700	JTK-04T	20.75	12.7	12.7	101.6	30	82.55	18	25	70.3	3.2	16	6-M5×0.8P(PCD Ø88.9)	4-M5×0.8P	6-Ø3.18	3-M5×0.8P(PCDØ88.9)
703702	JTK-06T	39.75	12.7	12.7	152.4	40	124.97	26	34.5	70.3	3.2	22	6-M6×1P(PCD Ø135.89)	8-M5×0.8P	6-Ø3.18	3-M6×1P(PCDØ135.89)
703704	JTK-08T	65.75	25.4	-	203.2	45	167.64	50	50	99.5	7.0	25	6-M10×1.5P(PCD Ø182.88)	4-M10×1.5P	4-Ø6.36	3-M8×1.25P(PCDØ182.88)

MODEL	T2	T3	R1	R2	R3	μ T.I.R Jaw T.I.R	Jaw Stroke (Diameter) (mm)	Repeatability	Gripping Force At Air Pressure kgf (0.7Mpa) (KN)	Max. Speed r.p.m(min ⁻¹)	Weight (kg)	Price
JTK-04T			30°			0.001	3	0.001	310 (3.1)	4500	4.4	
JTK-06T	3-M6×1P(PCDØ110)	3-M6×1P(PCDØ135.89)	30°	30°	45°	0.001	3	0.001	790 (7.8)	4500	9.8	
JTK-08T	3-M8×1.25P(PCDØ150)	3-M8×1.25P(PCDØ150)	30°	30°	30°	0.001	3	0.001	1450 (14.3)	4000	26.3	

3-JAW AIR CHUCK FIXTURES

>>Dimensions

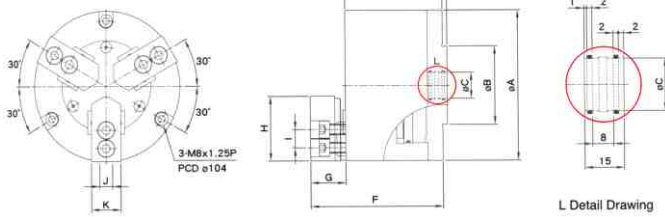

>>Specifications

Operation Example for rotary table



Operation Example for CNC Lathe



Order Number	MODEL	A	B	C	D	E	F	G	H	I	J	K	Piston Area (cm ²)	Plunger Stroke (mm)	Jaw Stroke (Diameter) (mm)	Gripping Force At Air Pressure 7kgf/cm ² (0.7Mpa) (kgf) (KN)	Max.Speed r.p.m.(min-1)	Gripping Range	Weight (kg)	Price
703800	JMR-04	117	60	20	3.5	74	100.7	26.7	49.5	14	10	23	57	9	3.8	1100 (10.8)	3000	Ø10~Ø117	5.7	JMR-04

3-JAW AIR CHUCK FIXTURES BUILT-IN 2 CYLINDERS

Order Number	MODEL	A	B	C	D	E	F	G	H	I	J	K	Piston Area (cm ²)	Plunger Stroke (mm)	Jaw Stroke (Diameter) (mm)	Gripping Force At Air Pressure 7kgf/cm ² (0.7Mpa) (kgf) (KN)	Max.Speed r.p.m.(min-1)	Gripping Range	Weight (kg)	Price
703850	JMR-04S	117	60	20	3.5	99.7	126.4	26.7	49.5	14	10	23	114	9	3.8	2200 (21.6)	4500	Ø10~Ø117	7.2	

Rotary Air Chuck Fixtures

It's Ideal for diving or cutting work pieces by mounting the chuck on indexing table or rotary table. The distinctive feature is that the chuck rotates with the spindle of indexing table or rotary table.

- Rustproof treated cylinder:**
The cylinder won't get rusty and seized even in wet or high moisture working environment.
- Dust and water proof cover:**
prevent metal chips or coolant from entering inside of chuck cylinder to maintain its accuracy and lead to longer service life.
- Integral pneumatic cylinder.**
Connect chuck and built-in cylinder to each other directly; thus enables operation stability. Moreover, it is more convenient for installation and operation since the use of draw tube and draw bar are no longer necessary.

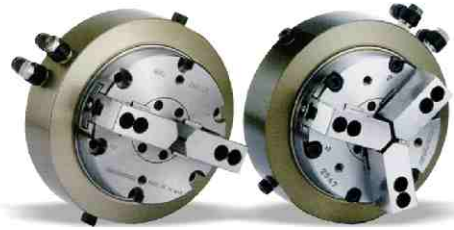

>> Dimensions

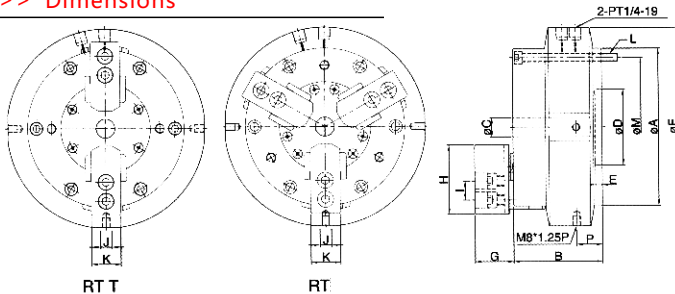

>>Specifications

>>Operation Example



Order Number	MODEL	A	B	C	D	E	F	G	H	I	J	K	L	M	P	Thru-Hole(Diameter)	(cm ²) Piston Area
703900	JRT-05	140	85	16	60	6	180	33	62	14	10	25	6-M8x1.25P	Ø118	27	16	74
703902	JRT-06	170	96	20	80	7	210	40	73	20	12	31	6-M8x1.25P	Ø147	27	20	120
703904	JRT-08	215	112	30	110	8	250	42	95	25	14	35	6-M10x1.5P	Ø185	28	30	190
703906	JRT-10	255	120	43	140	8	290	46	110	30	16	40	6-M10x1.5P	Ø220	30.5	43	280
703908	JRT-05T	140	85	16	60	6	180	33	62	14	10	25	6-M8x1.25P	Ø118	27	16	74
703910	JRT-06T	170	93	20	80	7	210	40	73	20	12	31	6-M8x1.25P	Ø147	27	20	120

MODEL	Plunger Stroke	Jaw Stroke(Diameter)	Max.Speed r.p.m.(min-1)	Max.Rressure kgf/cm ² (Mpa)	Gripping Force At Air Pressure 7kgf/cm ² (0.7Mpa) (kgf) (KN)	GrippingRange	(kg) Weight	Price
JRT-05	10	4.6	51	7 (0.7)	1340 (13.1)	Ø4-Ø136	9.3	
JRT-06	13	5.5	41	7 (0.7)	2330 (22.8)	Ø25-Ø166	15.5	
JRT-08	16	6.8	33	7 (0.7)	3730 (36.5)	Ø33-Ø215	28.5	
JRT-10	19	8.0	26	7 (0.7)	5480 (53.7)	Ø43-Ø255	42.3	
JRT-05T	10	4.6	51	7 (0.7)	1340 (13.1)	Ø4-Ø136	9.0	
JRT-06T	13	5.5	41	7 (0.7)	2330 (22.8)	Ø25-Ø166	15.0	

SUPER THIN CHUCK

SUPER THIN CHUCKS

1. The handle with an angle of 30 degrees is much convenient for operations
2. The "super thin thickness" design of chuck increase the "allowable distance" of machining operation.
3. Chuck flange makes loading and unloading operations simpler and more convenient.
4. Hard jaws and Soft jaws can be used alternatively.

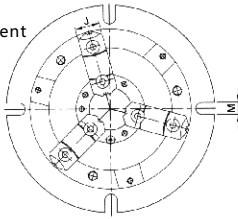

>>Dimensions

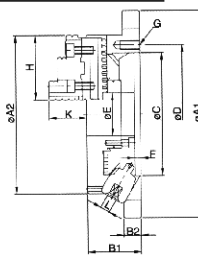

Unit:mm

Order NO.	Model	A1	A2	B1	B2	C	D	E	F	G	H	J	K	L	M	(kg)	O.D.C lamping (mm)	I.D.C lamping (mm)	Price
704100	NBK06	220	170	58	18	130	147	45	6	3-M10×1.5P	68	26	40	10	13	10.6	Ø8~Ø160	Ø48~Ø150	
704102	NBK08	270	210	65	20	155	172	60	6	3-M10×1.5P	82	28	43	11	13	18.1	Ø11~Ø200	Ø62~Ø190	
704104	NBK10	315	255	73	20	190	210	80	6	3-M12×1.75P	93	32	52	12	16	27.9	Ø12~Ø250	Ø72~Ø240	
704106	NBK12	370	305	80	22	250	285	105	5	3-M12×1.75P	118	40	59	14	18	42.9	Ø15~Ø300	Ø86~Ø290	

SUPER THIN SQUARE CHUCK

>> Dimensions

MC SQUARE CHUCKS

1. MC chucks are precisely ground, the tolerances of W,X,Y,Z among chucks are within 0.05mm.
2. Soft jaws can be used alternatively for machining special shaped work pieces, to substitute for designing and making a lot of jigs for this purpose.
3. The repetitive gripping accuracy with the hard jaws are within 0.02mm.
4. parallel gripping accuracy with hard jaws can be controlled within 0.05mm after aligning sides of chucks.

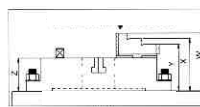
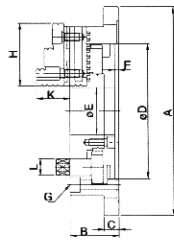
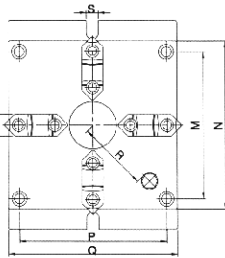

Unit:mm

>> Specifications

Order NO.	Model	A	B	C	D	E	F	G	H	J	K	L	M	N	P	Q	R	S	(kg)	O.D.C lamping (mm)	I.D.C lamping (mm)	Price
704200	MC06	215	57	18	130	40	5.5	4-M10×1.5P	68	26	39	14	144	165	144	165	66	18	11.4	Ø4~Ø128	Ø55~Ø128	
704202	MC08	250	65	20	160	55	6	4-M12×1.75P	82	28	43	17	174	200	174	200	83	18	18.6	Ø5~Ø162	Ø62~Ø162	
704204	MC10	310	72	22	200	70	6	4-M14×2P	93	32	50	21	218	250	218	250	104	18	31.6	Ø6~Ø200	Ø72~Ø200	
704206	MC12	380	85	25	260	100	7	4-M16×2P	117	40	56	23	274	310	274	310	135	22	56.6	Ø10~Ø265	Ø90~Ø265	

THIN CHUCK

>> Dimensions

SUPER THIN CHUCKS

1. By the compactness comes from "Light/Thin/Short" Small designing concept; the chucks are most fitting to hold work pieces for measuring.
2. Just rotate the chuck knob directly for gripping and Loosening. A handle is not necessary to be used.
3. Chuck body is made from very durable steel.
4. Jaws can be reversibly used. Gripping of various sizes becomes much convenient.
5. 2" chucks can even grip to 0.8mm small.

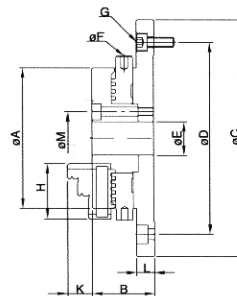
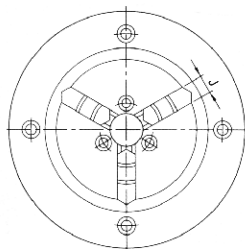

Unit:mm

>>Specifications

Order NO.	Model	A	B	C	D	E	F	G	H	J	K	L	M	(kg)	Max.Gripping Diameter		Price
															O.D.Clamping	I.D.Clamping	
704300	SE02	63	28	118	100	16	4	4-M5×0.8P	27	8	13	8	26	1.2	Ø0.8~Ø63	Ø23~Ø58	
704302	SE03	85	37	143	116	20	4	4-M6×1P	35	11	15	10.5	32	2.9	Ø1~Ø81	Ø31~Ø70	
704304	SE04	110	39	168	140	26	5	4-M6×1P	42	14	19	10	40	4.3	Ø1~Ø100	Ø36~Ø90	
704306	SE05	130	45	202	168	32	6	4-M8×1.25P	50	16	21	11.5	49	6.2	Ø1.5~Ø116	Ø43~Ø106	
704308	SE06	160	52	248	208	50	8	4-M10×1.5P	65	19	26	15	70	11.1	Ø1.5~Ø160	Ø52~Ø148	

3-JAWS REGULAR TYPE CHUCK

>>Dimensions

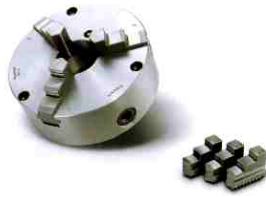
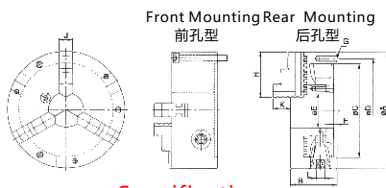

4-JAWS REGULAR TYPE CHUCK

Front Mounting Rear Mounting

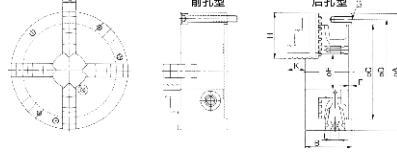

>>Specifications

Unit:mm

Order NO.	Model	A	B	C	D	E	F	G	H	J	K	L	(kg)	Max.Speed (r.p.m)	Max.Gripping Diameter		Price
															O.D.Clamping	I.D.Clamping	
705100	SC03	85	45	60	73	16	3.5	3-M6×1P	35	11	15	7	1.5	2500	Ø2-70	Ø24-64	
705102	SC04	112	58	80	95	24	4.5	3-M8×1.25P	42	14	17	8	3.3	2500	Ø3-90	Ø32-84	
705104	SC05	132	60	100	115	32	4.5	3-M8×1.25P	50	16	20	8	4.6	2500	Ø3-110	Ø35-110	
705106	SC06	167	66	130	147	45	5	3-M10×1.5P	65	19	23	10	7.9	2000	Ø4-160	Ø48-150	
705108	SC07	193	76	155	172	58	5	3-M10×1.5P	75	22	28	11	12.0	2000	Ø4-180	Ø56-170	
705110	SC08	103	76	160	176	58	5	3-M10×1.5P	75	22	28	11	13.3	2000	Ø4-180	Ø56-170	
705112	SC09	133	84	190	210	70	5.5	3-M12×1.75P	85	24	34.5	12	19.3	2000	Ø5-220	Ø62-210	
705114	SC10	273	86	230	250	89	5.5	3-M12×1.75P	98	28	39	12	26.2	1800	Ø6-260	Ø70-250	
705116	SC12	310	96	260	285	105	7	3-M12×1.75P	110	30	44	14	37.6	1800	Ø10-300	Ø86-290	
705118	SC16	405	122	345	375	160	8	3-M14×2P	146	40	56	15	80.7	1500	Ø14-400	Ø100-380	

4-JAWS REGULAR TYPE CHUCK

Unit:mm

Order NO.	Model	A	B	C	D	E	F	G	H	J	K	L	(kg)	Max.Speed (r.p.m)	Max.Gripping Diameter		Price
															O.D.Clamping	I.D.Clamping	
705200	PS07	193	76	155	172	58	5	3-M10×1.5P	75	22	28	11	12.1	2000	Ø4-180	Ø56-170	
705202	PS09	233	84	190	210	70	5.5	3-M12×1.75P	85	24	34.5	12	19.4	2000	Ø5-220	Ø62-210	
705204	PS12	310	96	260	285	105	7	3-M12×1.75P	110	30	45	14	38.1	1800	Ø10-300	Ø86-290	
705206	PS16	405	122	345	375	160	8	3-M14×2P	146	40	56	15	82.4	1500	Ø14-400	Ø100-280	

6-JAWS AWL TYPE CHUCK

>> Dimensions

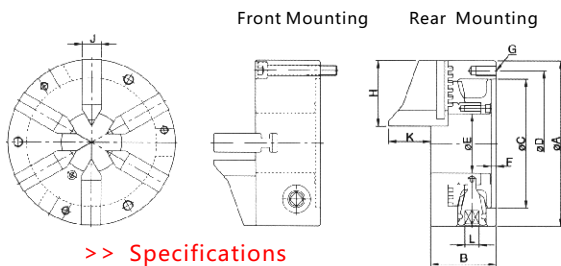

8-JAWS AWL TYPE CHUCK

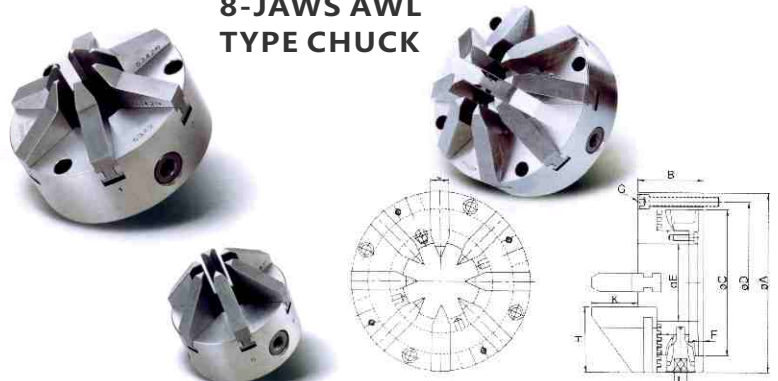

>> Specifications

Order NO.	Model	A	B	C	D	E	F	G	H	J	K	L	(kg)	Max.Speed (r.p.m)	Max.Gripping Diameter		Price
															O.D.Clamping	I.D.Clamping	
705300	AS04	112	58	80	95	32	4.5	3-M8×1.25P	45	14	46	8	3.8	1200	Ø2-32		
705302	AS06	167	65	130	147	60	5	3-M10×1.5P	66	19	43	10	8.4	1200	Ø4-60		

8-JAWS AWL TYPE CHUCK

Unit:mm

Order NO.	Model	A	B	C	D	E	F	G	H	J	K	L	(kg)	Max.Speed (r.p.m)	Max.Gripping Diameter		Price
															O.D.Clamping	I.D.Clamping	
705400	AE09	233	84	190	210	100	5.5	4-M12×1.75P	85	24	60	12	21	1000	Ø7-100		

3-JAWS POWERFUL TYPE

>>Dimensions

>>Specifications

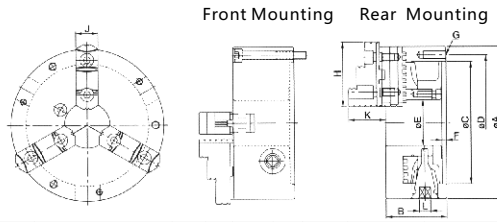

Unit:mm

Order NO.	Model	A	B	C	D	E	F	G	H	J	K	L	Max. Speed (r.p.m)	Max.Gripping Diameter		Price	
														O.D.Clamping (mm)	I.D.Clamping (mm)		
705500	SK06	167	66	130	147	45	5	3-M10×1.5P	68	26	39	10	8.6	2000	Ø8-160	Ø55-150	
705502	SK07	193	76	155	172	58	5	3-M10×1.5P	82	28	43	11	12.8	2000	Ø8-1800	Ø62-170	
705504	SK08	203	76	160	176	58	5	3-M10×1.5P	82	28	43	11	14.1	2000	Ø8-180	Ø62-170	
705506	SK09	233	84	190	210	70	5.5	3-M12×1.75P	93	32	50	12	20.4	2000	Ø11-220	Ø70-210	
705508	SK10	273	86	230	250	89	5.5	3-M12×1.75P	93	32	50	12	26.7	1800	Ø12-260	Ø80-250	
705510	SK12	310	96	260	285	105	7	3-M12×1.75P	118	40	56	14	39.3	1800	Ø15-300	Ø90-290	
705512	SK16	405	122	345	375	160	8.5	6-M14×2P	150	45	75.5	15	82.3	1500	Ø30-400	Ø110-380	

3-JAWS A1 TYPE CHUCK

>>Dimensions

>>Specifications

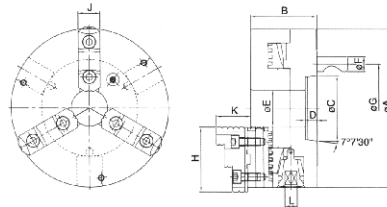

Unit:mm

Order NO.	Model	A	B	C	D	E	F	G	H	I	J	K	L	P	M	N	(kg)	Max. Speed (r.p.m)	Max.Gripping Diameter		Price
																			O.D.Clamping	I.D.Clamping	
705600	A,5-08"	200	83	33.5	61.9	40	Ø104.8	3-M10×1.5P	82	82.563	28	43	11	14.29	Ø16.3	6.8	17.4	2000	Ø8-180	Ø62-170	
705602	A,6-08"	200	83	33.5	82.6	56	Ø133.4	3-M12×1.75P	82	106.375	28	43	11	15.88	Ø19.3	6.8	30	2000	Ø11-220	Ø70-210	
705604	A,6-10"	255	91.5	36.5	82.6	56	Ø133.4	3-M12×1.75P	93	106.375	32	50	12	15.88	Ø19.3	6.8	30.6	1800	Ø15-300	Ø90-290	

POWERFUL 4-JAWS SCROLL TYPE

>>Specifications

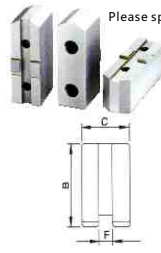
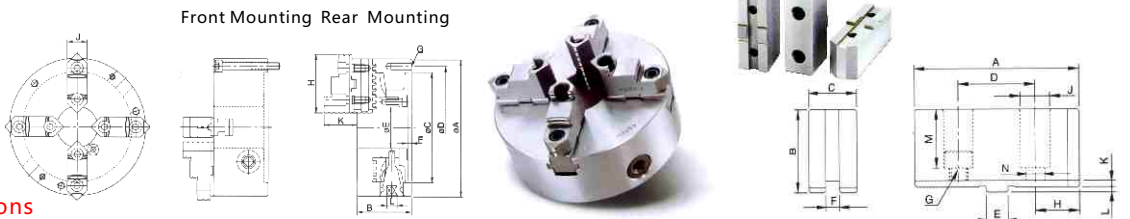

Please specify "front" or "back" when ordering"

Order NO.	Model	A	B	C	D	E	F	G	H	J	K	L	Max. Speed (r.p.m)	Max.Gripping Diameter		Price	
														O.D.Clamping (mm)	I.D.Clamping (mm)		
705700	PSK07	193	76	155	172	58	5	3-M10×1.5P	82	28	43	11	12.7	2000	Ø8-180	Ø62-170	
705702	PSK09	233	84	190	210	70	5	3-M12×1.75P	94	32	50	12	20.8	2000	Ø11-220	Ø70-210	
705704	PSK12	310	96	260	285	105	7	3-M12×1.75P	118	40	56	14	49	1800	Ø15-300	Ø90-290	
705706	PSK16	405	122	345	375	160	8.5	6-M14×2P	150	45	75.5	15	86.7	1500	Ø30-400	Ø110-380	

POWER SOFT JAWS

Please specify "front" or "back" when ordering"

Order NO.	MODEL	A	B	C	D	E	F	G	H	J	K	L	M	M	Weight(kg)	Price
705800	SO06Jaw	73	37	26	38.1	12.68	7.94	M8×1.25P	17.45	14	3.5	3	25	9	1.3	
705802	SO07 Jaw	95	48	31	44.4	12.68	7.94	M10×1.5P	25.3	17	3.8	3	34	11	2.6	
705804	SO09 Jaw	110	48	37	54	19.03	12.7	M12×1.75P	28	19	4.2	3	34	13	3.6	
705806	SO12 Jaw	125	54	42	63.5	19.03	12.7	M12×1.75P	30.75	19	4.2	3	38	13	5.5	
705808	SO16 Jaw	160	70	50	76.2	19.03	12.7	M16×2P	41.9	25	5.5	3	48	17	10.4	

2-JAW STEEL BODY CHUCKS

>>Dimensions

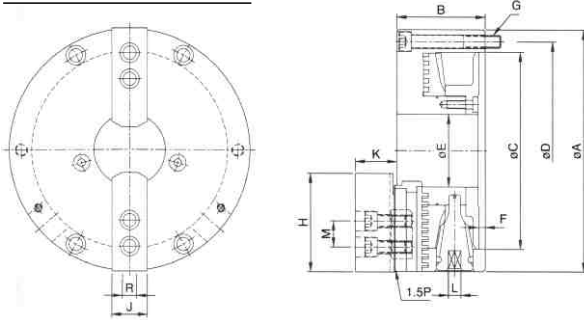

- 1.Can be used as a "Forming plate" for mach soft jaws.
- 2.Hard jaws and soft jaws can be adjusted just like on a power Chuck to increase the gripping
- 3.Hard jaws as well as Soft jaws are interchangeable with those of power chuck
- 4.Chuck Body is made of steel to enhance sa operations for high speed machining
- 5.The Chuck Handle can be operated easily smoothly



>> Illustrate

>> Specifications

The chuck can be used as a "Forming plate" for machining soft jaws. Top jaws can be adjusted back and forth easily, thus increasing gripping range. Hard jaws are interchangeable with those of power chucks. Soft jaws are interchangeable with those of power chucks. Optional accessory: Mounting plate.

Order Number	MODEL	A	B	C	D	E	F	G	H	J	K	L	M	R	Max.Speed r.p.m(min ⁻¹)	Max. Gripping Diameter		Weight(kg)	Price
																O.D.Clamping(mm)	I.D.Clamping(mm)		
706100	TNT-07	193	78	155	172	58	5	3-M10×1.5P	73	31	38	11	20	12	3200	Ø8~Ø235	Ø66~Ø235	14.4	
706102	TNT-09	233	85	190	210	70	5.5	3-M12×1.75P	95	35	40	12	25	14	2800	Ø11~Ø280	Ø85~Ø280	22.3	

3-JAW STEEL BODY CHUCKS

Order Number	MODEL	A	B	C	D	E	F	G	H	J	K	L	M	R	Max.Speed r.p.m(min ⁻¹)	Max. Gripping Diameter		Weight(kg)	Price
																O.D.Clamping(mm)	I.D.Clamping(mm)		
706200	NT-07	193	78	155	172	58	5	3-M10×1.5P	78	28	48	11	20	12	3200	Ø8~Ø235	Ø66~Ø235	13.1	
706202	NT-09	233	85	190	210	70	5.5	3-M12×1.75P	92	32	52	12	25	14	2800	Ø11~Ø280	Ø85~Ø280	21.2	
706204	NT-10	273	91	230	250	89	5.5	3-M12×1.75P	101.5	37	56	12	30	16	2400	Ø12~Ø330	Ø92~Ø330	30.5	
706206	NT-12	310	104	260	285	105	7	3-M12×1.75P	116	47	67	14	30	21	2100	Ø15~Ø370	Ø104~Ø370	46.1	

3-JAW ADJUSTMENT STEEL BODY SCROLL CHUCKS

>>Dimensions

>>Dimensions

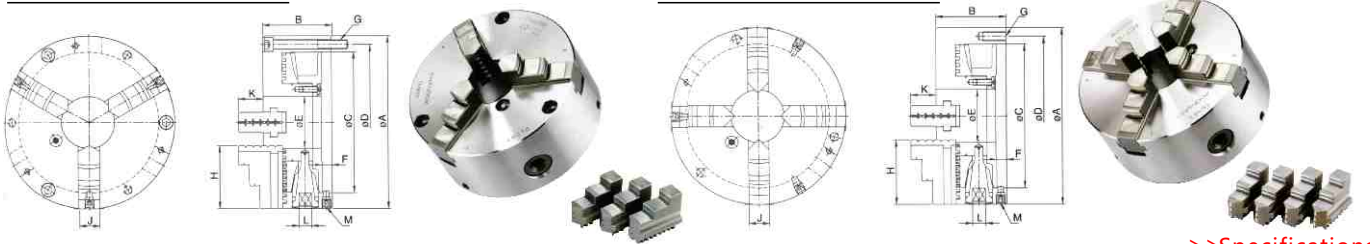

>>Specifications

Order Number	MODEL	A	B	C	D	E	F	G	H	J	K	L	M	Max.Speed r.p.m(min ⁻¹)	Max. Gripping Diameter		Weight (kg)	Price
															O.D.Clamping(mm)	I.D.Clamping(mm)		
706400	CT-06	167	75.5	130	147	45	12	3-M10×1.5P	65	22	28	10	3-M12×1.75P	4000	Ø4~Ø160	Ø48~Ø150	10.4	
706402	CT-07	193	85	155	172	58	12	3-M10×1.5P	75	24	28.5	11	3-M12×1.75P	3500	Ø4~Ø180	Ø56~Ø170	12.9	
706404	CT-09	233	92	190	210	70	12.5	3-M12×1.75P	85	28	33	12	3-M12×1.75P	2900	Ø5~Ø220	Ø62~Ø210	20.4	
706406	CT-10	275	98	230	250	89	12.5	3-M12×1.75P	98	30	38	12	3-M12×1.75P	2500	Ø6~Ø260	Ø70~Ø250	29.3	
706408	CT-12	310	111	260	285	105	14	3-M12×1.75P	110	32	45	14	3-M12×1.75P	2200	Ø10~Ø300	Ø86~Ø290	43.7	

4-JAW ADJUSTMENT STEEL BODY SCROLL CHUCKS

>>Specifications

Order Number	MODEL	A	B	C	D	E	F	G	H	J	K	L	M	Max.Speed r.p.m(min ⁻¹)	Max. Gripping Diameter		Weight (kg)	Price
															O.D.Clamping(mm)	I.D.Clamping(mm)		
706500	FCT-07	193	85	155	172	58	12	3-M10×1.5P	75	24	28.5	11	3-M12×1.75P	3500	Ø4~Ø180	Ø56~Ø170	13.2	
706502	FCT-09	233	92	190	210	70	12.5	3-M12×1.75P	85	28	33	12	3-M12×1.75P	2900	Ø5~Ø220	Ø62~Ø210	20.7	
706504	FCT-10	275	98	230	250	89	12.5	3-M12×1.75P	98	30	38	12	3-M12×1.75P	2500	Ø6~Ø260	Ø70~Ø250	29.8	
706506	FCT-12	310	111	260	285	105	14	3-M12×1.75P	110	32	45	14	3-M12×1.75P	2200	Ø10~Ø300	Ø86~Ø290	44.4	

2-JAW POWERFUL TYPE ADJUSTMENT STEEL BODY CHUCKS

>> Dimensions

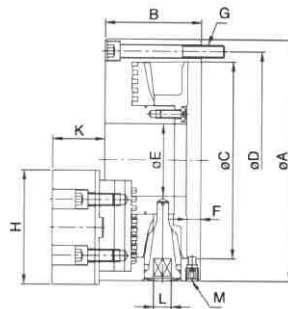
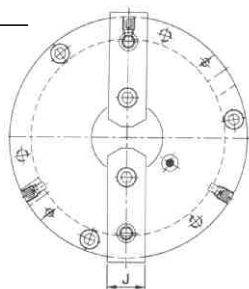

>> Specifications

Order Number	MODEL	A	B	C	D	E	F	G	H	J	K	L	M	Max.Speed r.p.m(min ⁻¹)	Max. Gripping Diameter		Weight (kg)	Price
															O.D.Clamping(mm)	I.D.Clamping(mm)		
706600	TKT-06	167	75.5	130	147	45	12	3-M10×1.5P	73	26	40.5	10	3-M12×1.75P	4000	Ø4~Ø160	Ø48~Ø150	10.4	
706602	TKT-07	193	85	155	172	58	12	3-M10×1.5P	95	31	49.5	11	3-M12×1.75P	3500	Ø4~Ø180	Ø56~Ø170	14.46	
706604	TKT-09	233	92	190	210	70	12.5	3-M12×1.75P	110	37	50	12	3-M12×1.75P	2900	Ø5~Ø220	Ø62~Ø210	22.4	

3-JAW POWERFUL TYPE ADJUSTMENT STEEL BODY CHUCKS

>>Dimensions

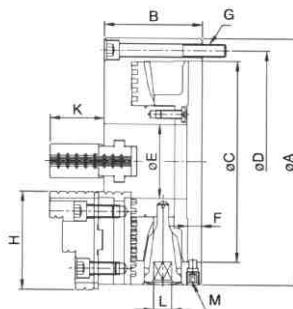
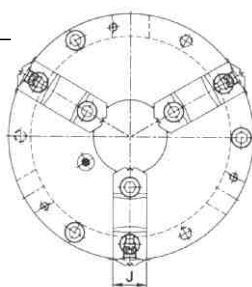

>> Specifications

Order Number	MODEL	A	B	C	D	E	F	G	H	J	K	L	M	Max.Speed r.p.m(min ⁻¹)	Max. Gripping Diameter		Weight (kg)	Price
															O.D.Clamping(mm)	I.D.Clamping(mm)		
701670	KT-06	167	75.5	130	147	45	12	3-M10×1.5P	68	26	40	10	3-M12×1.75P	4000	Ø8~Ø160	Ø55~Ø150	9.7	
706702	KT-07	193	85	155	172	58	12	3-M10×1.5P	82	28	43	11	3-M12×1.75P	3500	Ø8~Ø180	Ø62~Ø170	13.6	
706704	KT-09	233	92	190	210	70	12.5	3-M12×1.75P	93	32	51	12	3-M12×1.75P	2900	Ø11~Ø220	Ø70~Ø210	21.5	
706706	KT-10	275	98	230	250	89	12.5	3-M12×1.75P	102	35	54	12	3-M12×1.75P	2500	Ø12~Ø260	Ø80~Ø250	30.4	
706708	KT-12	310	111	260	285	105	14	3-M12×1.75P	118	40	58	14	3-M12×1.75P	2200	Ø15~Ø300	Ø90~Ø290	45.4	

4-JAW POWERFUL TYPE ADJUSTMENT STEEL BODY CHUCKS

>>Dimensions

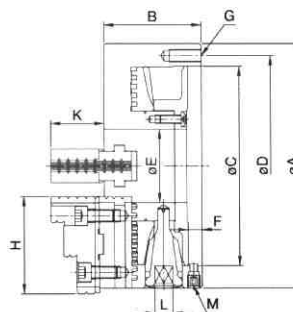
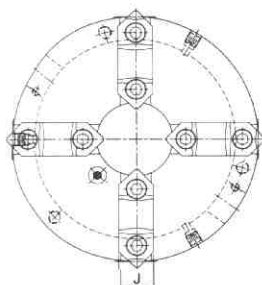

>> Specifications

Order Number	MODEL	A	B	C	D	E	F	G	H	J	K	L	M	Max.Speed r.p.m(min ⁻¹)	Max. Gripping Diameter		Weight (kg)	Price
															O.D.Clamping(mm)	I.D.Clamping(mm)		
706800	FKT-07	193	85	155	172	58	12	3-M10×1.5P	82	28	43	11	3-M12×1.75P	3500	Ø8~Ø180	Ø62~Ø170	14.1	
706802	FKT-09	233	92	190	210	70	12.5	3-M12×1.75P	93	32	51	12	3-M12×1.75P	2900	Ø11~Ø220	Ø70~Ø210	22	
706804	FKT-10	275	98	230	250	89	12.5	3-M12×1.75P	102	35	54	12	3-M12×1.75P	2500	Ø12~Ø260	Ø80~Ø250	33.5	
706806	FKT-12	310	111	260	285	105	14	3-M12×1.75P	118	40	58	14	3-M12×1.75P	2200	Ø15~Ø300	Ø90~Ø290	46.1	

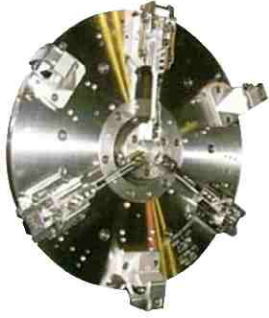

Hub chuck

The Name to Know in Wheel Chucks—For Passenger Cars, Light Trucks, Heavy Trucks, Buses & Motorcycles

LMC Workholding is rapidly becoming the market leader in workholding for the manufacture of wheels for passenger cars, light trucks, heavy trucks and buses. LMC is a partner in the Okuma Wheel Team which provides the bulk of wheel cell equipment worldwide. Okuma, LMC, Chiron and Fanuc Robotics make up the Wheel Team.

LMC has engineered new wheel chuck technologies to include quick change and lightweight models. Our engineering staff offers years of wheel chuck design and implementation experience. Years of hydraulic actuator and power chuck experience too. LMC also offers matching wheel chuck cylinders. Rely on LMC Workholding for your wheel production needs.

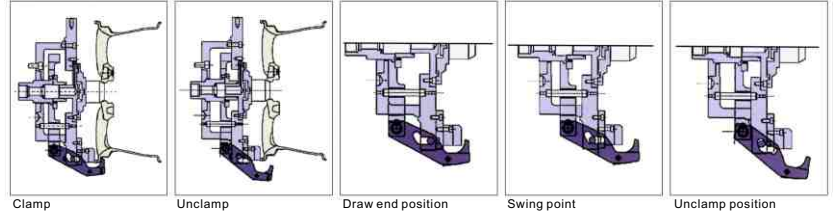

Wheel Diameter	Chuck Diameter			
	Small	Medium	Large	Very Large
25"				
24"				
23"			WTi-322	US-1524
22"			(Light Truck, Truck, Bus)	(Light Truck, Truck, Bus)
21"				
20"	WTi-310	US-1420	LPS	
19"				
18"	(Passenger Car, Light Truck)	(Passenger Car, Light Truck)	(Passenger Car, Light Truck)	
17"				
16"	2800rpm	2800rpm	2800rpm	
15"	Min.14" Max.20.5"	Min.14" Max.20.5"	Min.15" Max.20.5"	
14"				
13"				
12"				
11"				
10"				



Standard and Lightweight Series

This chuck, available in four models. Does it all. The WTi fits automobile and light truck wheels 149 to 209, truck and bus wheels up to 24.59. Contact LMC Workholding for the optimum clamping solution. US Series chucks are lightweight for increased spindle life and faster cycle times.

Optional part detection system, consisting of three air-activated plungers, senses whether or not the workpiece is properly seated, an essential component for any automatic/robot loaded application.

Next-generation cam arm design



Weight (Base Chuck Only)

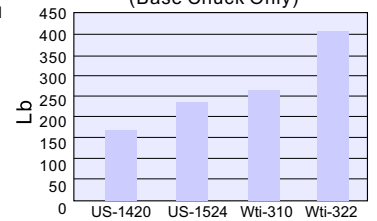

Rotational Inertia (Base Chuck Only)

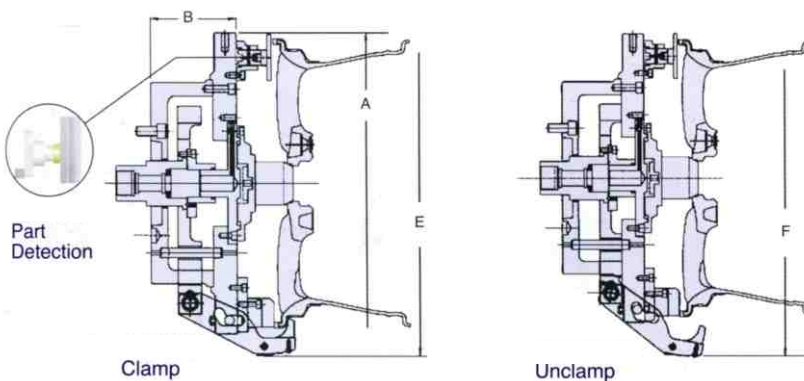
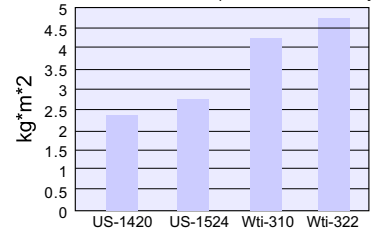

Model Number	Capacity Wheel Diameter	RPMs (max)	Drawbar Pull (lbs)	Drawbar Stroke (in/mm)	Spindle Mount	Chuck Weight (lbs)	A Dia (in/mm)	B Dia (in/mm)		
WTi-310/US-1420	14 to 20	2800	7700	1.38/35	A2-8	264/160	21.50/546.2	5.90/149.7		
WTi-322/US-1524	15 to 24.5	2200	7700	1.38/35	A2-11	410/240	26.00/660.0	7.85/199.5		
Model Number	SS-3/4EX		S-3/4EX		L-3/4EX		XL-3/4EX		Z-3/4EX*	
	E	F	E	F	E	F	E	F	E	F
WTi-310/US-1420	21.5/547	22.4/570	21.5/547	23.0/584	22.0/559	24.1/611	23.1/587	25.0/634	24.3/618	26.2/665
WTi-322/US-1524	26.0/660	26.5/673	26.0/660	27.5/698	26.6/675	28.5/724	27.6/702	29.5/749	28.6/727	30.5/774

Wheel Chuck



Lean Production Series

Adjusting a cam arm from one wheel diameter to another in seconds makes this chuck ideal for aftermarket wheel manufacturers and OEM suppliers who handle short-run specialty wheels. Each cam arm handles 6 ranges within 15" to 20" wheel size capacity. One: Insert wrench. Two: Crank cam arms to desired diameter. Three: Remove wrench.

The LPS Series for automobiles and light trucks allows for variations in raw castings as well as for new "fashion" wheel designs where material is added to the raw casting for first operation holding.

>> Operation Example



>> Dimensions

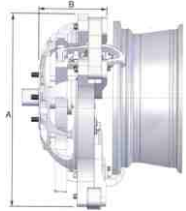

>> Specifications

Model Number	Capacity	Wheel Diameter	RPM's (max)	Drawbar Pull (lbs)	Drawbar Stroke (in/mm)
LPS-1520	15" to 20"		2800	7700	1.38/35
Model Number	Spindle Mount	Chuck Weight (lbs)	A Dia (in/mm)	B Dia (in/mm)	
LPS-1520	A2-8	300	29.45/748.0	7.32/186.0	

Special cylinder for hub chuck



Chuck Actuators

LMC Workholding offers two chuck actuators specifically designed for wheel chuck applications like yours. These hydraulic cylinders offer optimum hydraulic system pressure settings for the fastest clamping/unclamping action available. And their shorter lengths and lighter weights enhance lathe acceleration and deceleration while improving machine dynamics.

Model 2R 120 is a single-motion cylinder ideal for applications that use solid mandrels or spring rings for wheel centering. RNW is a dual-function cylinder that is ideal for applications that actuate a collet or a small three-jaw chuck for wheel centering.

>> Dimensions

RNW 40

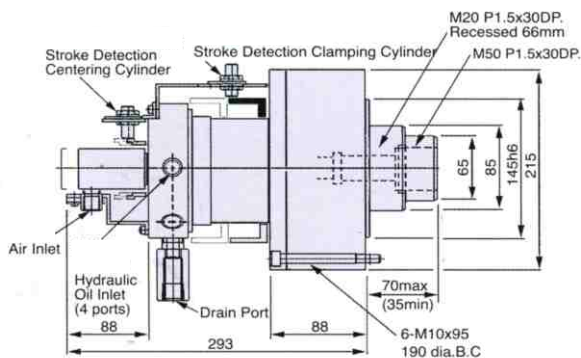

2R 120

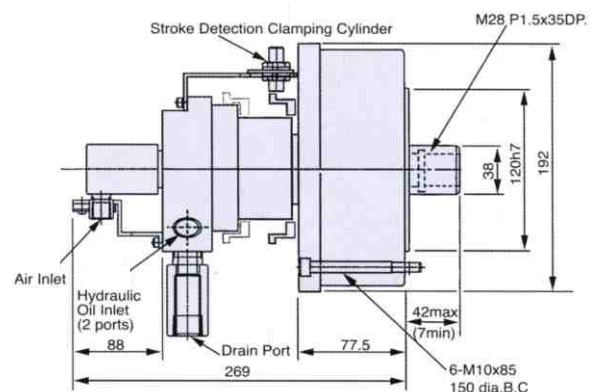

>> Specifications

Model Number	Length (mm)	Stroke Time(sec)	Clamping Cylinder		
			Bore×Stroke(mm)	Piston Area(in ² /cm ²)	
2R-120	269	1.6	120×35	15.8/102	
RNW 40	293	2.3(0.4)	146×35	17.2/111	
Model Number	Centering Cylinder		Max. oper. Pressure	RPMs	Cylinder Weight
	Bore×Stroke(mm)	Piston Area(in ² /cm ²)	(b/in ² -kgf/cm ²)	(Max)	(lbs)
2R-120	n/a	n/a	568/40	5000	33
RNW 40	50×12	1.2/8	568/40	4000	50

AIR FEED TUBE

>>Dimensions

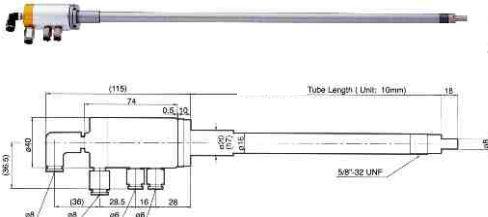

>>Specifications

Order Number	MODEL	Max.Speed	Recommended Lubricant	Price
707100	JTB-XX-18	8000min ⁻¹	VG6 or Equal	8000min ⁻¹
707102	JTB-XX-30	8000min ⁻¹	VG6 or Equal	8000min ⁻¹

AIR FEED TUBE (FOR GRINDING MACHINES)



>>Dimensions

Ex. Fill in 50 for required length of 500mm.
30mm is optional for the length of 8 fitting.

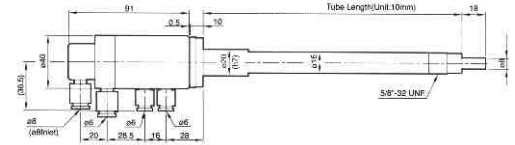

>>Specifications

Order Number	MODEL	Max.Speed	Recommended Lubricant	Price
8000min ⁻¹	JTBC-XX-18	8000min ⁻¹	VG6 or Equal	
8000min ⁻¹	JTBC-XX-30	8000min ⁻¹	VG6 or Equal	

MOUNTING PLATES

>> Dimensions

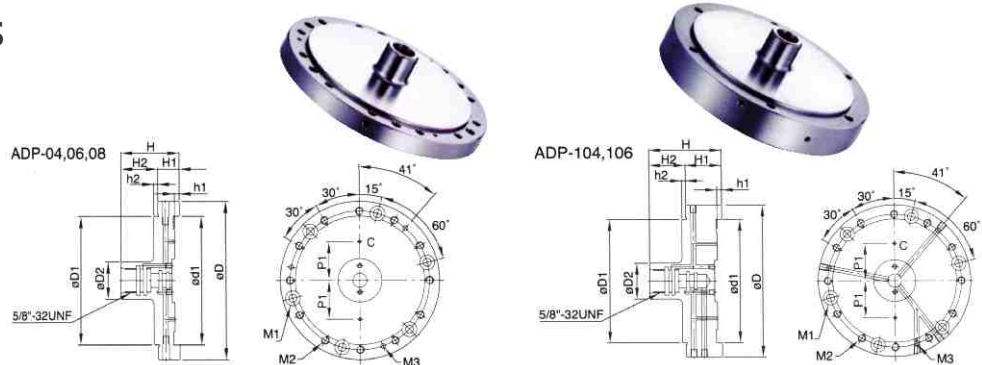

>> Specifications

Order Number	MODEL	D	D1(h7)	D2	d1(H7)	P1	H	H1	H2	h1	h2	M1	M2	M3	Price
707200	FLP-04	101.6	82.55	24	82.55	25	38	14	24	3.2	2.5	6-M5×0.8P (PCD Ø88.9)	12-M5×0.8P (PCD Ø88.9)	3-Ø3(PCD Ø88.9)	
707202	FLP-06	152.4	124.97	24	124.97	34.5	38	14	24	3.2	2.5	6-M6×1P (PCD Ø135.89)	12-M6×1P (PCD Ø135.89)	3-Ø4(PCD Ø135.89)	
707204	FLP-08	203.2	167.64	30	167.64	50	54	25	29	7.0	5.0	6-M10×1.5P (PCD Ø182.88)	6-M10×1.5P (PCD Ø182.88)	3-Ø4(PCD Ø182.88)	
707206	FLP-104	101.6	82.55	24	82.55	25	48	24	24	3.2	2.5	6-M5×0.8P (PCD Ø88.9)	12-M5×0.8P (PCD Ø88.9)	3-Ø3(PCD Ø88.9)	
707208	FLP-106	152.4	124.97	24	124.97	34.5	48	24	24	3.2	2.5	6-M6×1P (PCD Ø135.89)	12-M6×1P (PCD Ø135.89)	3-Ø3(PCD Ø135.89)	

SOFT JAWS FOR SUPER PRECISION CHUCKS

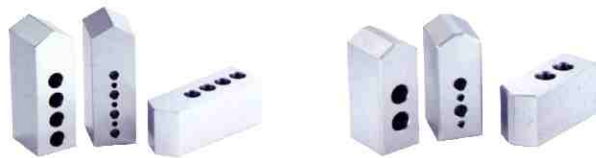

>> Dimensions

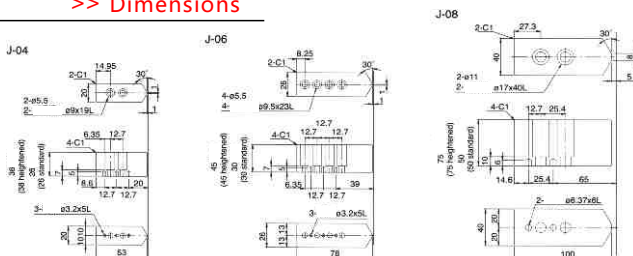

AIR FEED TUBE



>> Dimensions

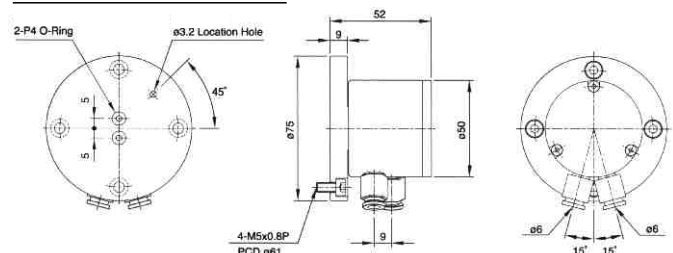

FORMING RINGS (FOR SOFT JAWS OF SUPER PRECISION AIR CHUCKS)

>> Dimensions

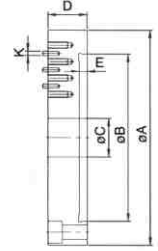
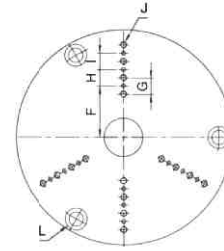

>>Specifications

Order Number	MODEL	A	B	C	D	E	F	G	H	I	J	K	L	Weight(kg)	Price
707300	JFR-04	112	80	22	30	6	21	12.7	12.7	12.7	6-M5×0.8P	9-Ø3.175	3-M8×1.25P	1.9	
707302	JFR-06	167	130	30	30	6	40	12.7	12.7	12.7	12-M5×0.8P	9-Ø3.175	3-M10×1.5P	4.3	
707304	JFR-08	203	160	54	35	6	66	25.4	25.4	-	6-M10×1.5P	6-Ø6.35	3-M10×1.5P	7.2	

BAR STOPPER

>> Dimensions

Dimension E: Join to inside diameter of drawtube.

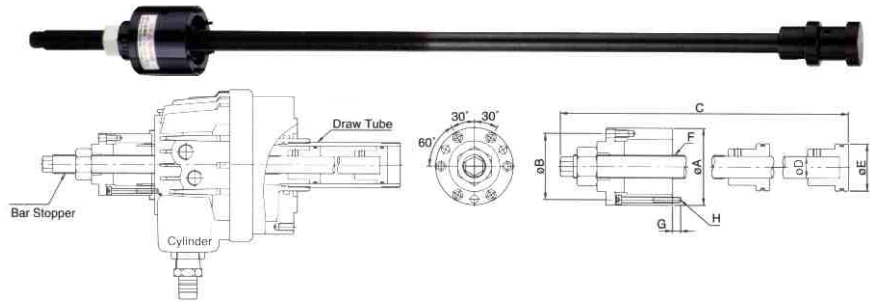

>> Specifications

Order Number	MODEL	A	B	C	D	F	G	H	Max.Speed r.p.m.(min)	Stroke	Matching Cylinder	Price
707400	JPE-06	76	64	910	24	W1"-12	9	6-M6×1P×55	3000	350	SH1246	
707402	JPE-08	85	73	1010	24	W1"-12	9	6-M6×1P×65	2400	400	SH1562	
707404	JPE-10	108	98	1310	24	W1"-12	9	6-M6×1P×65	2000	400	SH1875	
707406	JPE-12	120	108	1310	32	M33×2P	9	6-M6×1P×70	1600	400	SH2091	
707408	JPE-15	160	148	1310	32	M33×2P	13	6-M6×1P×75	1200	400	SH2511	

Soft Jaw (SJ-SERIES) For Hydraulic Chucks

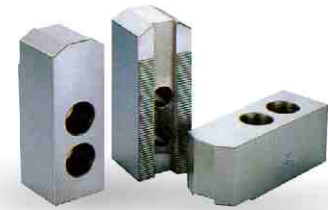

>> Dimensions

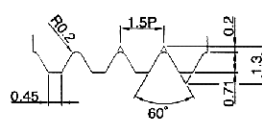
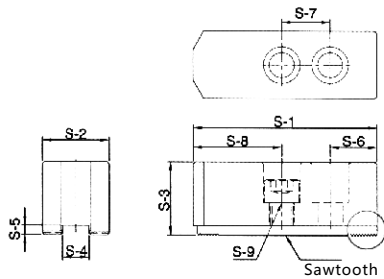

Pitch 1.5 Sawtooth

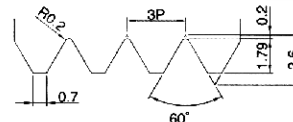

Pitch 3.0 Sawtooth

>> Specifications

Order Number	MODEL	S-1	S-2	S-3	S-4	S-5	S-6	S-7	S-8	S-9	Serration Pitch	Weight(kg)	Price
707100	SZ-04	49.5	23	23	10	4.5	10	14	25.5	M8X1.25P	1.5X60°	0.42	
707102	SZ-05	62	25	30	10	4.5	10	14	38	M8X1.25P	1.5X60°	0.85	165
707104	SZ-06	73	31	36	12	5	15	20	38	M10X1.5P	1.5X60°	1.5	200
707106	SZ-08	95	35	38	14	5	24	25	46	M12X1.75P	1.5X60°	2.4	250
707108	SZ-10	110	40	42	16	5	30	30	50	M12X1.75P	1.5X60°	3.6	300
707110	SZ-12	129	50	50	21(18)	6	39	30	60	M16X2P(M14x2P)	1.5X60°	6.1	450
707112	SZ-15	165	62	62	22(25.5)	8(5)	37	43	85	M20X2.5P	1.5X60°	12.5	
707114	SZ-18	165	62	62	22(25.5)	8(5)	37	43	85	M20X2.5P	1.5X60°	12.5	
707116	SZ-21	180	65	70	25	9	40	60	80	M20X2.5P	3.0X60°	16.2	
707118	SZ-24	180	65	70	25	9	40	60	80	M20X2.5P	3.0X60°	16.2	

Special Soft Jaw For Hydraulic Chucks

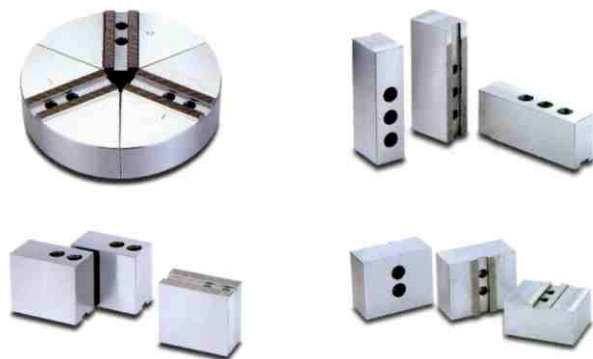

Tip Angle	5 inch Heightening Specifications			6 inch Heightening Specifications			8 inch Heightening Specifications			10 inch Heightening Specifications			12 inch Heightening Specifications			
	Order Number	Specifications	Price	Order Number	Specifications	Price	Order Number	Specifications	Price	Order Number	Specifications	Price	Order Number	Specifications	Price	
60°	707200	SZ5C60	185	707220	SZ6C60	220	707244	SZ8C60	270	707276	SZ10C60	340	707304	SZ12C60	490	
90°	707202	SZ5C90	175	707222	SZ6C90	210	707246	SZ8C90	260	707278	SZ10C90	320	707306	SZ12C90	465	
120°	707204	SZ5C120	165	707224	SZ6C120	200	707248	SZ8C120	250	707280	SZ10C120	300	707308	SZ12C120	450	
120°	707206	SZ5C120H40	300	707226	SZ6C120H50	350	707250	SZ8C120H40	350	707282	SZ10C120H50	400	707310	SZ12C120H60	600	
	707208	SZ5C120H50	350	707228	SZ6C120H60	400	707252	SZ8C120H50	400	707284	SZ10C120H60	450	707312	SZ12C120H70	700	
	707210	SZ5C120H60	400	707230	SZ6C120H70	450	707254	SZ8C120H60	450	707286	SZ10C120H70	550	707314	SZ12C120H80	750	
	707212	SZ5C120H70	450	707232	SZ6C120H80	500	707256	SZ8C120H70	500	707288	SZ10C120H80	600	707316	SZ12C120H90	950	
	707214	SZ5C120H80	650	707234	SZ6C120H90	550	707258	SZ8C120H80	550	707290	SZ10C120H90	700	707318	SZ12C120H100	1100	
	707216	SZ5C120H90	750	707236	SZ6C120H100	600	707260	SZ8C120H90	600	707292	SZ10C120H100	800	707320	SZ12C120H120	1200	
	707218	SZ5C120H100	850	707238	SZ6C120H120	800	707262	SZ8C120H100	700	707294	SZ10C120H120	900	707322	SZ12C120H150	1400	
					707240	SZ6C120H130	900	707264	SZ8C120H120	750	707296	SZ10C120H140	1000			
					707242	SZ6C120H150	1000	707266	SZ8C120H130	800	707298	SZ10C120H150	1150			
								707268	SZ8C120H140	900	707300	SZ10C120H180	1600			
								707270	SZ8C120H150	1000	707302	SZ10C120H200	1800			
								707272	SZ8C120H180	1400						
							707274	SZ8C120H200	1650							

Hard Jaw (HJ-SERIES)For Hydraulic Chucks

>> Dimensions

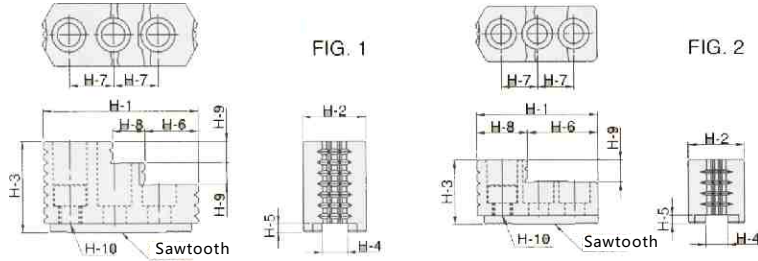

>> Specifications

Order Number	MODEL	H-1	H-2	H-3	H-4	H-5	H-6	H-7	H-8	H-9	H-10	Serration Pitch	Weight(kg)	Reference Drawing	Price
707400	YZ4C	53	23	28	10	4	29	14	24	10	M8x1.25P	1.5X60°	0.4	Fig.2	
707402	YZ5C	53	23	28	10	4	29	14	24	10	M8x1.25P	1.5X60°	0.4	Fig.2	1900
707404	YZ6C	67	31	36	12	5	39	20	28	12	M10x1.5P	1.5X60°	0.95	Fig.2	2100
707406	YZ8C	87	35	51	14	5	29.5	25	18	12	M12x1.75P	1.5X60°	1.9	Fig.1	2400
707408	YZ10C	101	40	54	16	5	45.5	30	18	13	M12x1.75P	1.5X60°	2.8	Fig.1	3000
707410	YZ12C	108	50	67	21(18)	4(5)	49	30	20	16	M16x2P(M14x2P)	1.5X60°	3.5	Fig.1	
707412	YZ15C	143	62	86	22(25.5)	8(5)	55	43	38	20	M20x2.5P	1.5X60°	9.5	Fig.1	
707414	YZ18C	143	62	86	22(25.5)	8(5)	55	43	38	20	M20x2.5P	1.5X60°	9.5	Fig.1	
707416	YZ21C	159.5	80	90	25	9	97.5	50	62	40	M20x2.5P	3X60°	15.3	Fig.2	
707418	YZ24C	159.5	80	90	25	9	97.5	50	62	40	M20x2.5P	3X60°	15.3	Fig.2	

SOFT JAWS FOR PULL BACK POWER CHUCKS

>> Dimensions

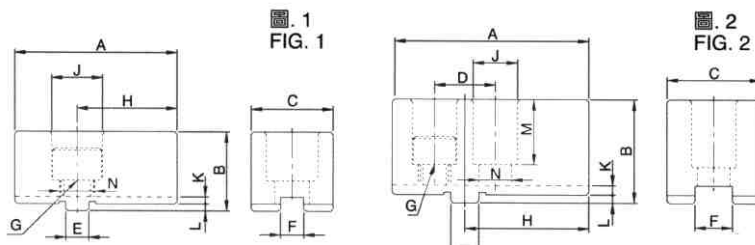

MOUNTING PLATES

Mounting plates are available to any kinds of spindle noses.



>> Specifications

>> Dimensions

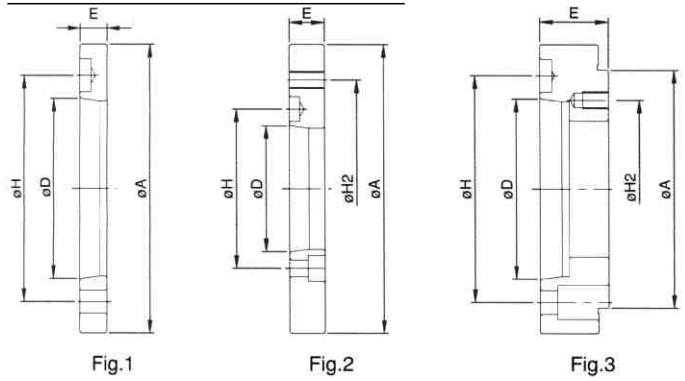

Order Number	MODEL	Nose of Spindle D	A	H	H2	E	Reference Drawing	Price
707500	JT005A ₂ 4	A ₂ 4	110	82.6	--	20	-1 Fig-1	300
707502	JT006A ₂ 5	A ₂ 5	140	104.8	--	15	-1 Fig-1	300
707504	JT008A ₂ 6	A ₂ 6	170	133.4	--	17	-1 Fig-1	400
707506	JT010A ₂ 8	A ₂ 8	220	171.4	--	18	-1 Fig-1	500
707508	JT012A ₂ 8	A ₂ 8	220	171.4	--	18	-1 Fig-1	
707510	JT015A ₂ 11	A ₂ 11	300	235	--	22	-1 Fig-1	
707512	JT018A ₂ 11	A ₂ 11	300	235	--	22	-1 Fig-1	
707514	JT021A ₂ 15	A ₂ 15	380	300.2	--	27	-1 Fig-1	
707516	JT024A ₂ 20	A ₂ 20	520	463.6	--	27	-1 Fig-1	

Order Number	MODEL	Nose of Spindle D	A	H	H2	E	Reference Drawing	Price
707600	JT005A ₂ 5	A ₂ 5	110	104.8	82.6	45	-3 Fig-3	400
707602	JT006A ₂ 4	A ₂ 4	140	82.6	104.8	20	-2 Fig-2	
707604	JT006A ₂ 6	A ₂ 6	140	133.4	104.8	40	-2 Fig-2	
707606	JT08A ₂ 8	A ₂ 8	170	171.4	133.4	45	-2 Fig-2	600
707608	JT08A ₂ 5	A ₂ 5	170	104.8	133.4	23	-2 Fig-2	
707610	JT010A ₂ 6	A ₂ 6	220	133.4	171.4	28	-2 Fig-2	750
707612	JT012A ₂ 6	A ₂ 6	220	133.4	171.4	28	-2 Fig-2	
707614	JT012A ₂ 11	A ₂ 11	220	235	171.4	54	-2 Fig-2	
707616	JT015A ₂ 8	A ₂ 8	300	171.4	235	33	-2 Fig-2	
707618	JT018A ₂ 8	A ₂ 8	300	171.4	235	33	-2 Fig-2	
707620	JT021A ₂ 11	A ₂ 11	380	235	330.2	41	-2 Fig-2	
707622	JT024A ₂ 11	A ₂ 11	520	235	463.6	45	-2 Fig-2	
707624	JT024A ₂ 15	A ₂ 15	520	330.2	463.6	42	-2 Fig-2	

BAR PULLERS FOR CNC LATHES



>> Dimensions

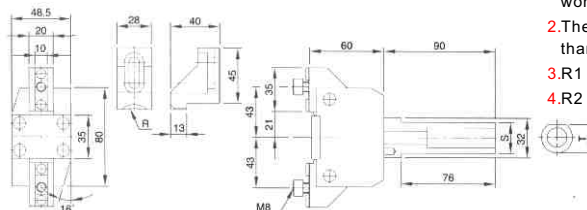

Bar Puller is great for installing on the turret of CNC Lathes or other Automatic special purpose machines to substitute for automatic bar feeder. For the repetitive pulling length is very accurate; the use of Bar Puller is a very convenient and effective alternative for automatic machines.

Application:

- 1.The opening of bar puller shall be 3~5 mm less than the diameter of work piece.
- 2.The gripping length has to be more than 16mm from chuck surface.
- 3.R1 Gripping range:12~26mm.
- 4.R2 Gripping range:27~46mm.

R		S	T
R1	R2		
16	32	32	31.5
16	32	25	24.5

SHB Sleeve

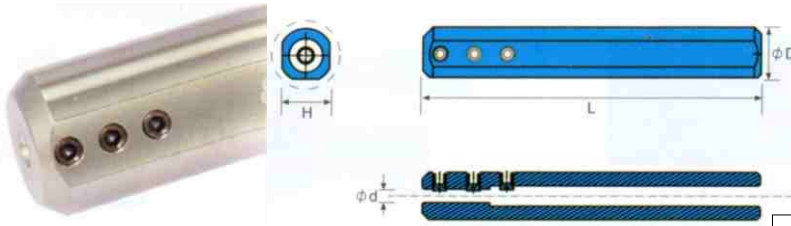

Shank	Model No	Stock	Dimension (mm)				Assembly Holder	(Parts)		Order Number	Price
			ØD	Ød	L	H		Screw	Wrench		
								T			
Steel	SHB-1602	•	16	2	100	15	C02	JM40	L2	708100	200
	SHB-1603	•	16	3	100	15	C03			708102	200
	SHB-1604	•	16	4	100	15	C04/H04			708104	200
	SHB-1605	•	16	5	100	15	C05/H05			708106	200
	SHB-1606	•	16	6	100	15	C06/H06			708108	200
	SHB-1607	•	16	7	100	15	C07/S08			708110	200
	SHB-1608	•	16	8	100	15	C08/S08	JM60	L3	708112	200
	SHB-1610	•	16	10	100	15	C10/S10			708114	200
	SHB-2004	•	20	4	100	18	C04			708116	250
	SHB-2005	•	20	5	100	18	C05			708118	250
	SHB-2006	•	20	6	100	18	C06			708120	250
	SHB-2008	•	20	8	100	18	C08/S08			708122	250
	SHB-2010	•	20	10	100	18	C10/S10	JM60	L3	708124	250
	SHB-2012	•	20	12	100	18	C12/S12			708126	250
	SHB-2204	•	22	4	100	20	C04	JM40	L2	708128	300
	SHB-2205	•	22	5	100	20	C05			708130	300
	SHB-2206	•	22	6	100	20	C06			708132	300
	SHB-2208	•	22	8	100	20	C08/S08	JM60	L2	708134	300
	SHB-2210	•	22	10	100	20	C10/S10			708136	300
	SHB-2212	•	22	12	100	20	C12/S12			708138	300
SHB-2216	•	22	16	100	20	C16/S16	708140			300	

MTHR Lathe Quick Center Block

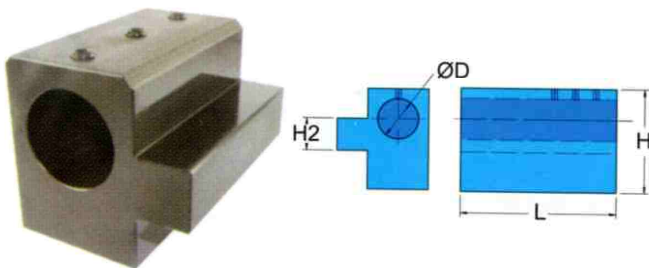

Order Number	Model No	Stock	Dimension (mm)					Price
			D	L	L1	H	H2	
708200	MTHR2032	•	32	80	18	64	20	500
708202	MTHR2532	•	32	80	18	64	25	500
708204	MTHR2540	•	40	90	30	76	25	500
708206	MTHR3240	•	40	90	30	76	32	500
708210	MTHR2040	•	40	90	30	76	20	500

MCH Centre-drill Holder

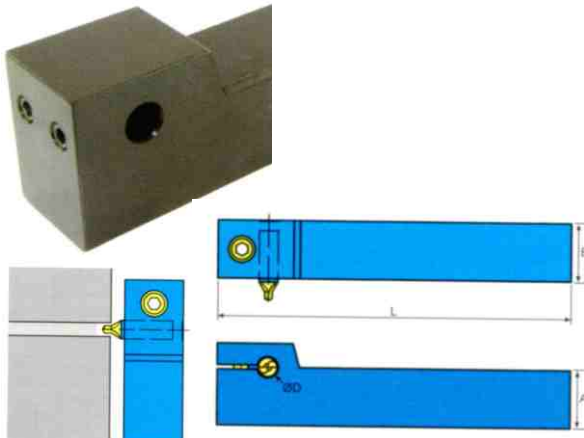

Order Number	Model No	Stock	Dimension (mm)					(Parts)		Price
			D	A	B	L	H1	Screw	Wrench	
									T	
708220	MCH2020K-05	•	5	20	20	125	20	FS40	L2	500
708222	MCH2020K-06	•	6	20	20	125	20	FS50	L2.5	500
708224	MCH2020K-08	•	8	20	20	125	20	FS60	L3	500
708226	MCH2020K-10	•	10	20	20	125	20	FS80	L4	500
708228	MCH2525M-05	•	5	25	25	150	25	FS40	L2	500
708230	MCH2525M-06	•	6	25	25	150	25	FS50	L2.5	500
708232	MCH2525M-08	•	8	25	25	150	25	FS60	L3	500
708234	MCH2525M-10	•	10	25	25	150	25	FS80	L4	500

Sleeve

FIG-1

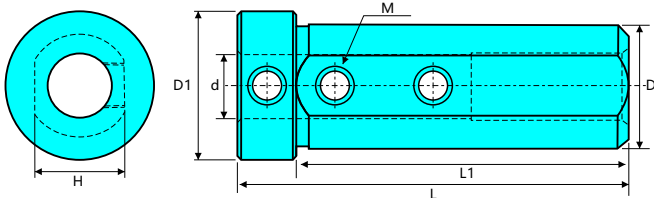
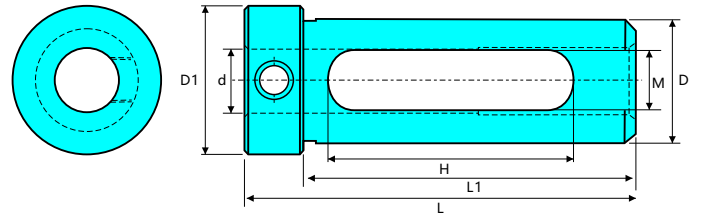

FIG-2



Order Number	Model No	Stock	Dimension (mm)							Fig	Price			
			d	D	L	L1	D1	H	M					
708300	D16-T03	●	3	16	62	55	19	14.5	M4	1	300			
708302	D16-T04	●	4						M4		250			
708304	D16-T05	●	5						M5		250			
708306	D16-T06	●	6						M5		250			
708308	D16-T07	●	7				M6	250						
708310	D16-T08	●	8				M6	250						
708312	D16-T10	●	10				24.5	M6	250					
708314	D16-T12	●	12				19	50	M4		2	250		
708316	D20-T02	●	2	20	67	60	27	17.5	9	1	300			
708318	D20-T03	●	3						300					
708320	D20-T04	●	4						200					
708322	D20-T05	●	5						200					
708324	D20-T06	●	6						200					
708326	D20-T07	●	7						200					
708328	D20-T08	●	8						200					
708330	D20-T09	●	9						200					
708332	D20-T10	●	10						200					
708334	D20-T12	●	12						200					
708336	D20-T13	●	13						200					
708338	D20-T14	●	14						40		13	2	200	
708340	D20-T16	●	16						200					
708342	D20-MTA1	●	MTA1						-		-	300		
708344	D20-MTA2	●	MTA2	-	-	300								
708346	D25-T04	●	4	25	64	58	35	23.5	M6	1	200			
708348	D25-T05	●	5								200			
708350	D25-T06	●	6								200			
708352	D25-T07	●	7								200			
708354	D25-T08	●	8								200			
708356	D25-T09	●	9								200			
708358	D25-T10	●	10								200			
708360	D25-T12	●	12								200			
708362	D25-T13	●	13								200			
708364	D25-T14	●	14								200			
708366	D25-T16	●	16								200			
708368	D25-T18	●	18								51	12	2	200
708370	D25-T20	●	20								200			
708372	D25-T22	●	22								200			
708374	D25-MTA1	●	MTA1								-	-	300	
708376	D25-MTA2	●	MTA2								-	-	300	

Order Number	Model No	Stock	Dimension (mm)							Fig	Price			
			d	D	L	L1	D1	H	M					
708400	D32-T04	●	4	32	85	70	38	29.5	M6	1	200			
708402	D32-T05	●	5								200			
708404	D32-T06	●	6								200			
708406	D32-T07	●	7								200			
708408	D32-T08	●	8								200			
708410	D32-T09	●	9								200			
708412	D32-T10	●	10		85	55	38	29.5	M8	1	200			
708414	D32-T12	●	12								200			
708416	D32-T13	●	13								200			
708418	D32-T14	●	14								200			
708420	D32-T16	●	16								200			
708422	D32-T18	●	18								200			
708424	D32-T20	●	20								77	14	2	200
708426	D32-T22	●	22											200
708428	D32-T25	●	25	-	-	-	-	-	-	200				
708430	D32-MTA1	●	MTA1							300				
708432	D32-MTA2	●	MTA2							300				
708434	D32-MTA3	●	MTA3	300										
708436	D40-T04	●	4	40	100	85	46	38	M8	1	250			
708438	D40-T05	●	5								250			
708440	D40-T06	●	6								250			
708442	D40-T07	●	7								250			
708444	D40-T08	●	8								250			
708446	D40-T09	●	9								250			
708448	D40-T10	●	10					77	14	2	250			
708450	D40-T12	●	12								250			
708452	D40-T13	●	13								250			
708454	D40-T14	●	14								250			
708456	D40-T16	●	16								250			
708458	D40-T18	●	18								250			
708460	D40-T20	●	20								-	-	-	250
708462	D40-T22	●	22											250
708464	D40-T25	●	25	-	-	-	-	-	-	250				
708466	D40-T30	●	30							250				
708468	D40-T32	●	32							250				
708470	D40-MTA1	●	MTA1	350										
708472	D40-MTA2	●	MTA2	350										
708474	D40-MTA3	●	MTA3	350										
708476	D40-MTA4	●	MTA4	350										
708478	D50-T08	●	8	50	100	85	58	48	M8	1	500			
708480	D50-T10	●	10								500			
708482	D50-T12	●	12								500			
708484	D50-T16	●	16								500			
708486	D50-T20	●	20					77	14	2	500			
708488	D50-T25	●	25								500			
708490	D50-T32	●	32								500			
708492	D50-T40	●	40								500			
708494	D50-MTA3	●	MTA3								500			
708496	D50-MTA4	●	MTA4								500			
708498	D50-MTA5	●	MTA5	500										

Lathe parts

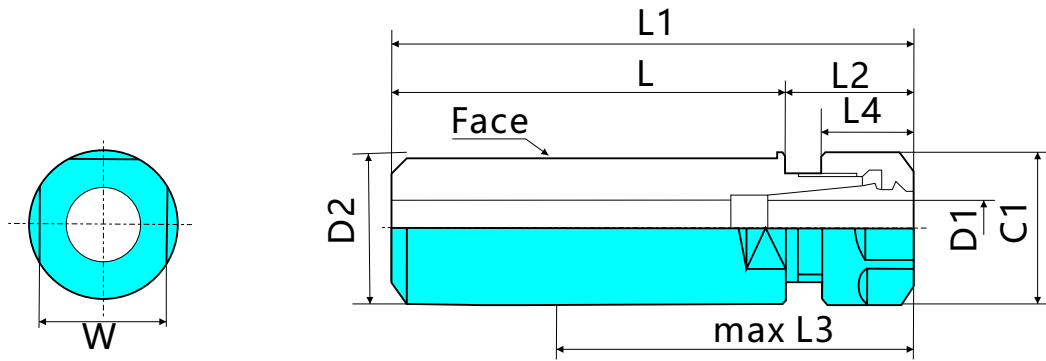

Order Number	Model No	Stock	Dimension (mm)								Collet	Nut Wrench	Price
			L	L1	L2	max L3	L4	C1	D1	D2			
708500	SSH16-ECH7-32	●	32	48	16	35	11.5	23	0.5-7	16	AR11	FK-3	300
708502	SSH16-ECH7-70	●	70	94	24	55							300
708504	SSH20-ECH7-45	●	45	61	16	45							300
708506	SSH20-ECH7-70	●	70	94	24	55							300
708508	SSH20-ECH7-105	●	105	129	24	70	17	32	0.5-10	20	AR16	FK-4	300
708510	SSH20-ECH10-40	●	40	63	23	45							300
708512	SSH20-ECH10-70	●	70	105	35	70							300
708514	SSH20-ECH10-105	●	105	140	35	80							300
708516	SSH20-ECH13-70	●	70	106	36	75	19	36	1-13	25	AR20	FK-5	300
708518	SSH25-ECH7-62	●	62	86	24	55	11.5	23	0.5-7		AR11	FK-3	400
708520	SSH25-ECH10-70	●	70	105	35	70	17	32	0.5-10		AR16	FK-4	400
708522	SSH25-ECH10-105	●	105	140	35	80	20	43	1-16		AR25	FK-6	400
708524	SSH25-ECH13-70	●	70	106	36	75	19	36	1-13	32	AR20	FK-5	400
708526	SSH25-ECH16-70	●	70	110	40	80	20	43	1-16		AR25	FK-6	400
708528	SSH32-ECH13-80	●	80	116	36	75	19	36	1-13		AR20	FK-5	500
708530	SSH32-ECH16-80	●	80	120	40	80	20	43	1-16		AR25	FK-6	500
708532	SSH32-ECH20-80	●	80	128	48	100	23	51	2-20	40	AR32	FK-8	500
708534	SSH40-ECH20-80	●	80	128	48	100							600
708536	SSH40-ECH20-110	●	110	158	48	100							600

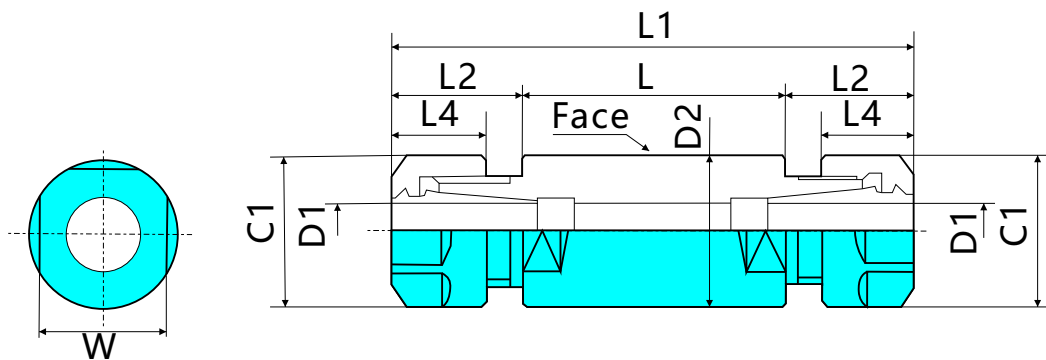

Order Number	Model No	Stock	Dimension (mm)							Collet	Nut Wrench	Price						
			L	L1	L2	C1	L4	D1	D2									
708600	SSH20-ECH7WS-33	●	33	65	16	19	11.5	0.5-7	20	AR11	SP-17A	500						
708602	SSH20-ECH7WS-53	●	53	85								500						
708604	SSH3/4-ECH7WS-33	●	33	65								500						
708606	SSH3/4-ECH7WS-53	●	53	85								500						
708608	SSH22-ECH10WM-70	●	70	122	26	22	18	0.5-10	22	AR16	AE-16M	600						
708610	SSH22-ECH10WM-85	●	85	137								600						
708612	SSH22-ECH7WMS-100	●	100	142.5								16.5	19	11.5	0.5-7	AR11	AP-17A	600
708614	SSH22-ECH10WMS-100	●	100	142.5								26	22	18	0.5-10	AR16	AE-16M	600
708616	SSH32-ECH13WM-55	●	55	109	27	28	19	1-13	32	AR20	AE-20M	800						
708618	SSH32-ECH13WM-85	●	85	138	27	28	19					800						

COLLET HOLDER FOR COOLANT

It is used together with a coolant collet.

A piping screw is in the back or the side of a holder.

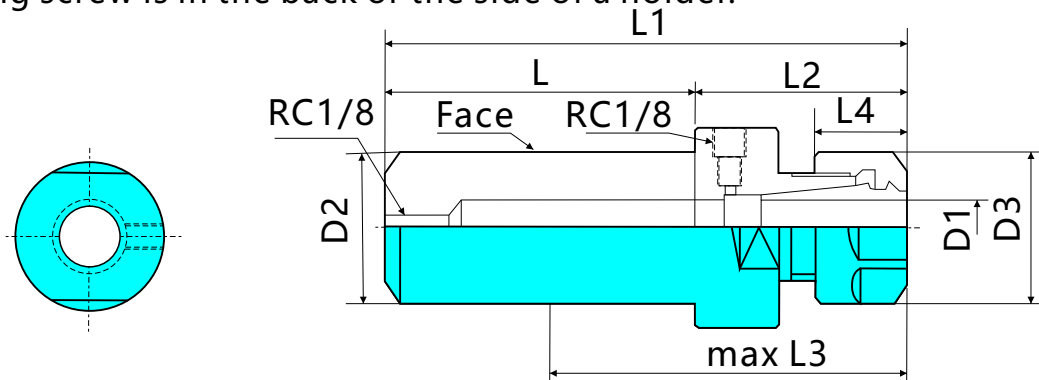

Order Number	Model No	Stock	Dimension (mm)								Collet	Nut Wrench	Price			
			L	L1	L2	max L3	L4	D3	D1	D2						
708700	SSH20-ECH7OH-40	●	70	106	36	83	11.5	23	0.5-7	20	AR11	FK-3	400			
708702	SSH20-ECH10OH-40	●	40	85	45	55	17	32	0.5-10		AR16	FK-4	400			
708704	SSH20-ECH10OH-70	●	70	115	45	85					AR20	FK-5	400			
708706	SSH20-ECH13OH-70	●	70	117.5	47.5	85	19	36	1-13	25	AR16	FK-4	500			
708708	SSH25-ECH10OH-70	●	70	115	45	85	17	32	0.5-10					AR20	FK-5	500
708710	SSH25-ECH10OH-105	●	105	150	45	95								19	36	1-13
708712	SSH25-ECH13OH-70	●	70	117.5	47.5	85	19	36	1-13	32	AR20	FK-5	600			
708714	SSH25-ECH16OH-70	●	70	121	51	85	20	43	1-16					AR25	FK-6	500
708716	SSH32-ECH13OH-75	●	75	122.5	47.5	85	19	36	1-13					AR32	FK-8	600
708718	SSH32-ECH16OH-75	●	75	126	51	85	20	43	1-16	19.05	AR16	FK-4	400			
708720	SSH32-ECH20OH-75	●	75	134	59	90	23	51	2-20					25.4	500	
708722	SSH3/4-ECH10OH-105	●	105	150	45	94	17	32	0.5-10					19.05	AR16	FK-4
708724	SSH1-ECH10OH-105	●	105	150	45	94				25.4	500					

COLLET HOLDER FOR COOLANT

It is used together with a coolant collet.

A piping screw is in the back or the side of a holder.

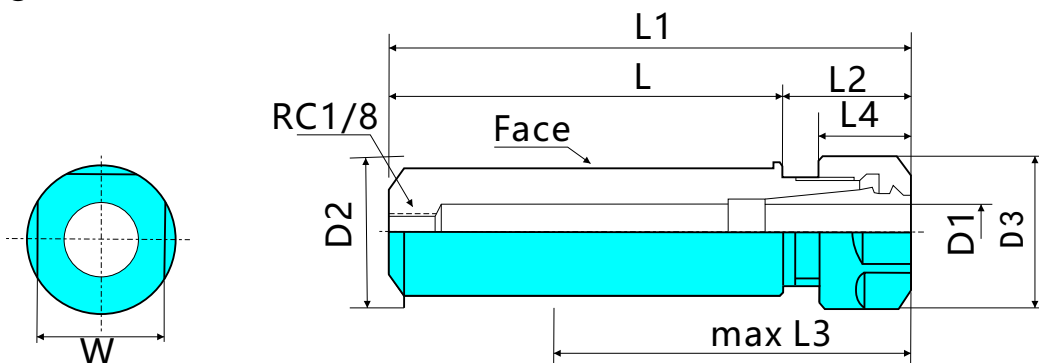

Order Number	Model No	Stock	Dimension (mm)								D2	Collet	Nut Wrench	Price			
			L	L1	L2	max L3	L4	D3	D1	D2							
708800	SSH20-ECH7SOH-40	●	40	56	16	33	11.5	19	0.5-7	20	17	AR11	SP-17A	350			
708802	SSH20-ECH10SOH-40	●	40	62	22	36	17	28	0.5-10						AR16	SP-25	350
708804	SSH20-ECH10SOH-70	●	70	90	22	66									AR20	SP-30	450
708806	SSH25-ECH10SOH-40	●	40	63	23	37	19	34	1-13	25	22	AR16	SP-25	450			
708808	SSH25-ECH10SOH-50	●	50	73	23	47									AR20	SP-30	450
708810	SSH25-SOH13SOH-50	●	50	73.5	23.5	46									AR32	FK-7	500
708812	SSH32-ECH20SOH-80	●	80	115	35	75	23	50	2-20	32	36	AR32	FK-7	500			

STANDARD LIVE CENTER

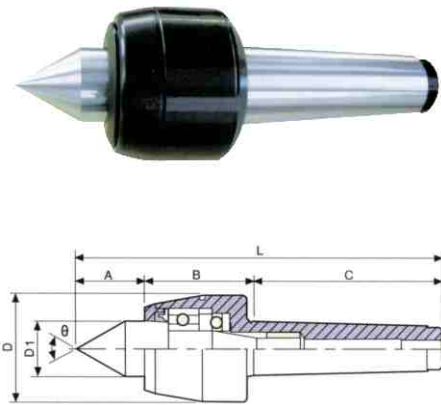

Order Number	Model	A	B	C	D	D1	d	L	Accuracy	θ	Weight kgs		Price
709100	BZ-MT.3H	39	55	86	53	30	-	180	0.005	60°	1.28kgs	Carbide	
709102	BZ-MT.4H	42	62	108	63	32	-	208	0.005	60°	2.20kgs		
709104	BZ-MT.5H	49	71	136	83	40	-	256	0.005	60°	4.33kgs		
709106	BZ-MT.5H	80	110	189	128	70	-	379	0.008	60°	14.2kgs		
709108	BZ-MT.1B	17	43	70	35	15	-	120	0.005	60°	0.75kgs	Standard	
709110	BZ-MT.2B	24	41	80	45	20	-	145	0.005	60°	0.95kgs		
709112	BZ-MT.3B	39	55	86	53	30	-	180	0.005	60°	1.28kgs		
709114	BZ-MT.4B	42	62	108	63	32	-	208	0.005	60°	2.20kgs		
709116	BZ-MT.5B	49	71	136	83	40	-	256	0.005	60°	4.33kgs	Slightness	
709118	BZ-MT.6B	80	110	189	128	70	-	379	0.008	60°	14.2kgs		
709120	BZ-MT.3X	45	55	86	53	30	10	186	0.005	60°	1.28kgs		
709122	BZ-MT.4X	52	62	108	63	32	12	218	0.005	60°	2.20kgs		
709124	BZ-MT.5X	59	71	136	83	40	14	266	0.005	60°	4.42kgs		

STANDARD HEAVY-DUTY LIVE CENTER

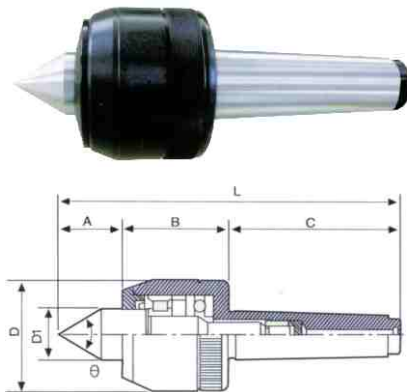

Order Number	Model	A	B	C	D	D1	d	L	Accuracy	θ	Weight kgs		Price
709200	ZXB-MT.3H	35	65	86	64	25	-	186	0.005	60°	1.9kgs	Carbide	
709202	ZXB-MT.4H	41	74	108	73	32	-	223	0.005	60°	2.85kgs		
709204	ZXB-MT.5H	49	78	136	94	40	-	263	0.005	60°	5.6kgs		
709206	ZXB-MT.3B	35	65	86	64	25	-	186	0.005	60°	1.9kgs	Standard	
709208	ZXB-MT.4B	41	74	108	73	32	-	223	0.005	60°	2.85kgs		
709210	ZXB-MT.5B	49	78	136	94	40	-	263	0.005	60°	5.6kgs		

HIGH-SPEED PRECISION LIVE CENTER

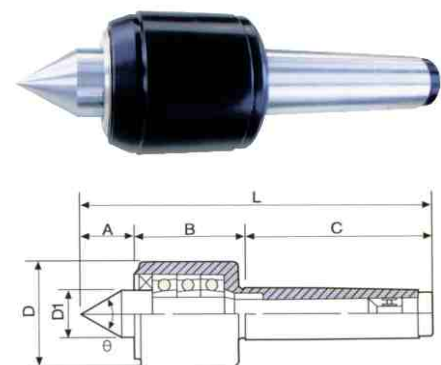

Order Number	Model	A	B	C	D	D1	d	L	Accuracy	θ	Weight kgs		Price
709300	GS-MT.3H	38	58	86	48	30	-	182	0.005	60°	1.25kgs	Carbide	
709302	GS-MT.4H	45	65	108	62	32	-	215	0.005	60°	2.22kgs		
709304	GS-MT.5H	50	70	136	72	40	-	256	0.005	60°	3.60kgs		
709306	GS-MT.3B	38	58	86	48	30	-	182	0.005	60°	1.25kgs	Standard	
709308	GS-MT.4B	45	65	108	62	32	-	215	0.005	60°	2.22kgs		
709310	GS-MT.5B	50	70	136	72	40	-	256	0.005	60°	3.60kgs		
709312	GS-MT.3C	48	58	86	48	30	10	192	0.005	60°	1.28kgs	Slightness	
709314	GS-MT.4C	52	65	108	62	32	12	225	0.005	60°	2.26kgs		
709316	GS-MT.5C	60	70	136	72	40	14	266	0.005	60°	3.66kgs		

LARGE-DUTY LIVE CENTER

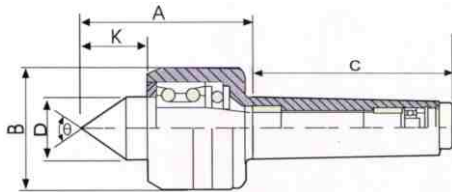

Order Number	Model	MT6-6T	MT6-8T	MT6-10T	M80-8T	M80-10T	M80-12T	Price
709400	(kg)	6000	8000	10000	8000	10000	12000	
709402	(mm)	0.01	0.01	0.01	0.01	0.01	0.01	
709404	A	196	215	215	196	215	257	
709406	B	140	160	180	160	180	200	
709408	D	60	70	80	70	80	85	
709410	K	62	68	77	68	77	86	
709412	θ	60°	60°	60°	60°	60°	60°	

SIDES LIVE CENTER

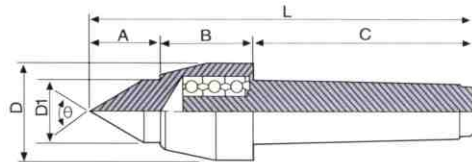

Order Number	Model	A	B	C	D	D1	d	L	Accuracy	θ	Weight kgs		Price
709500	WX-MT.3H	39	55	86	53	45	-	180	0.005	60°	1.28kgs	Carbide	
709502	WX-MT.4H	42	62	108	63	53	-	208	0.005	60°	2.20kgs		
709504	WX-MT.5H	49	71	136	83	68	-	256	0.005	60°	4.33kgs		
709506	WX-MT.3B	39	55	86	53	45	-	180	0.005	60°	1.28kgs	Standard	
709508	WX-MT.4B	42	62	108	63	53	-	208	0.005	60°	2.20kgs		
709510	WX-MT.5B	49	71	136	83	68	-	256	0.005	60°	4.33kgs		
709512	WX-MT.3X	45	55	86	53	45	10	186	0.005	60°	1.28kgs	Slightness	
709514	WX-MT.4X	52	62	108	63	53	12	218	0.005	60°	2.20kgs		
709516	WX-MT.5X	59	71	136	83	68	14	266	0.005	60°	4.42kgs		

SIDES LIVE CENTER

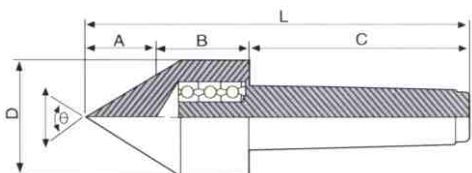

Order Number	Model	A	B	C	D	D1	d	L	Accuracy	θ	Weight kgs		Price
709600	WX-MT.3C	28	55	86	60	-	-	169	0.005	60°	1.8kgs	Standard	
709602	WX-MT.4C	30	62	108	80	-	-	196	0.005	60°	2.4kgs		
709604	WX-MT.5C	34	71	136	120	-	-	266	0.005	60°	5.0kgs		

LIVE CENTER

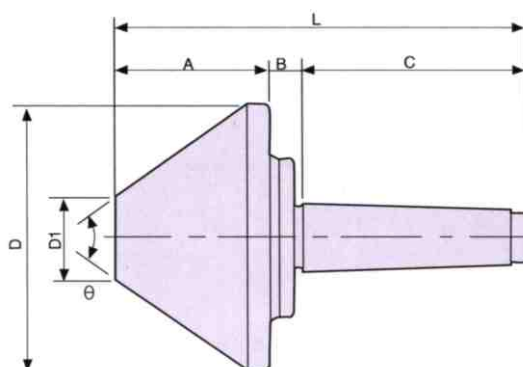

BULL NOSE CENTER

Order Number	Model	A	B	C	D	D1	L	Accuracy	θ	Weight kgs	Price
709700	SX 63-MT.2	46	17	69	60	12	132	0.005	60°	0.9kgs	
709702	SX 63-MT.3	46	17	86	60	12	149	0.005	60°	1.0kgs	
709704	SX 78-MT.3	52	18	86	80	15	156	0.005	70°	1.3kgs	
709706	SX 106-MT.3	59	16	86	100	25	161	0.008	70°	2.7kgs	
709708	SX 63-MT.4	46	17	108	60	12	171	0.005	60°	1.0kgs	
709710	SX 78-MT.4	52	18	108	80	15	178	0.005	70°	1.45kgs	
709712	SX 106-MT.4	59	16	108	100	25	183	0.008	70°	3.0kgs	
709714	SX 128-MT.4	73	12	108	130	40	193	0.008	70°	4.8kgs	
709716	SX 156-MT.4	88	12	108	150	45	208	0.010	70°	7.6kgs	
709718	SX 206-MT.4	98	12	108	200	81	218	0.010	70°	17kgs	
709720	SX 258-MT.4	107	13	108	250	92	228	0.015	80°	27kgs	
709722	SX 128-MT.5	73	12	136	130	40	221	0.008	70°	5.8kgs	
709724	SX 156-MT.5	88	12	136	150	45	236	0.010	70°	8.5kgs	
709726	SX 206-MT.5	98	12	136	200	81	246	0.015	70°	18kgs	
709728	SX 258-MT.5	107	13	136	250	92	256	0.015	80°	28kgs	
709730	SX 306-MT.5	107	30	136	300	120	273	0.020	90°	37.5kgs	
709732	SX 206-MT.6	98	12	190	200	81	300	0.010	70°	20.6kgs	
709734	SX 258-MT.6	107	13	190	250	92	310	0.015	80°	30.6kgs	
709736	SX 306-MT.6	107	30	190	300	120	327	0.020	90°	40kgs	

DEAD CENTER

CARBIDE HALF-NOTCHED CENTER

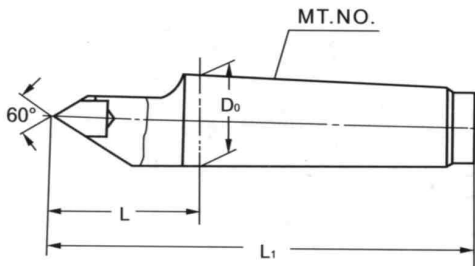

Order Number	Model & Specification	Taper	do	D1	L1	Price
709800	D142	MT.2	17.780	36	100	100
709802	D143	MT.3	23.825	44	125	125
709804	D144	MT.4	31.267	58	160	160
709806	D145	MT.5	44.399	70	200	200
709808	D146	MT.6	63.348	98	280	280

DEAD CENTER

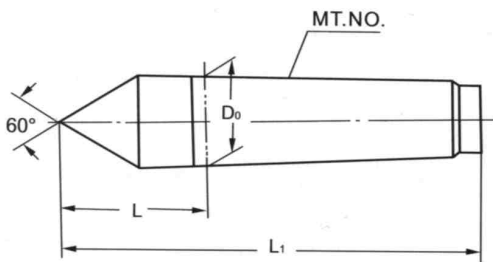

Order Number	Model & Specification		Taper	do	D1	L1	Price
	Ordinary Class	Accurate Class					
709810	D11φ4	D11φ4	1:20	4	10	33	33
709812	D11φ6	D11φ6		6	15	47	47
709814	D11φ80	D11φ80		80	119	315	315
709816	D11φ100	D11φ100		100	128	360	360
709818	D110	D110	MT.0	9.045	20	70	70
709820	D111	D111	MT.1	12.065	26	80	80
709822	D112	D112	MT.2	17.780	36	100	100
709824	D113	D113	MT.3	23.825	44	125	125
709826	D114	D114	MT.4	31.267	58	160	160
709828	D115	D115	MT.5	44.399	70	200	200
709830	D116	D116	MT.6	63.348	98	280	280

CARBIDE DEAD CENTER

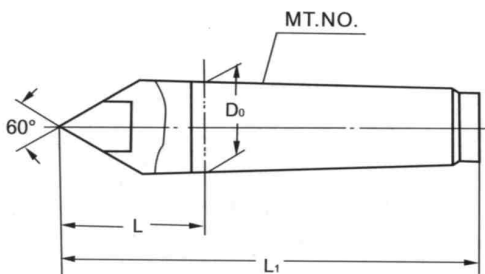

Order Number	Model & Specification	Taper	do	D1	L1	Price
709840	D121	MT.1	12.065	26	80	80
709842	D122	MT.2	17.780	36	100	100
709844	D123	MT.3	23.825	44	125	125
709846	D124	MT.4	31.267	58	160	160
709848	D125	MT.5	44.399	70	200	200
709850	D126	MT.6	63.348	98	280	280

HALF-NOTCHED CENTER

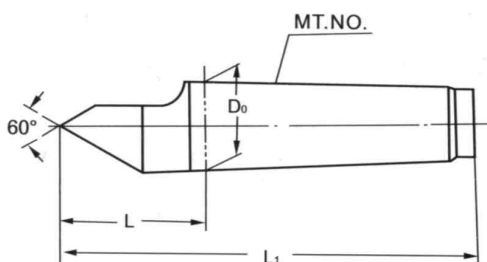

Order Number	Model & Specification		Taper	do	D1	L1	Price
	Ordinary Class	Accurate Class					
709852	D130	DM130	MT.0	9.045	20	70	70
709854	D131	DM131	MT.1	12.065	26	80	80
709856	D132	DM132	MT.2	17.780	36	100	100
709858	D133	DM133	MT.3	23.825	44	125	125
709860	D134	DM134	MT.4	31.267	58	160	160
709862	D135	DM135	MT.4	44.399	70	200	200
709864	D136	Dm136	MT.6	63.348	98	280	280